

User Manual



**DS1001A/DS1001G
Television Demodulators**

071-0905-01

Copyright © Tektronix, Inc. All rights reserved.

Tektronix products are covered by U.S. and foreign patents, issued and pending. Information in this publication supercedes that in all previously published material. Specifications and price change privileges reserved.

Tektronix, Inc., P.O. Box 500, Beaverton, OR 97077

TEKTRONIX and TEK are registered trademarks of Tektronix, Inc.

WARRANTY

Tektronix warrants that the products that it manufactures and sells will be free from defects in materials and workmanship for a period of one (1) year from the date of shipment. If a product proves defective during this warranty period, Tektronix, at its option, either will repair the defective product without charge for parts and labor, or will provide a replacement in exchange for the defective product.

In order to obtain service under this warranty, Customer must notify Tektronix of the defect before the expiration of the warranty period and make suitable arrangements for the performance of service. Customer shall be responsible for packaging and shipping the defective product to the service center designated by Tektronix, with shipping charges prepaid. Tektronix shall pay for the return of the product to Customer if the shipment is to a location within the country in which the Tektronix service center is located. Customer shall be responsible for paying all shipping charges, duties, taxes, and any other charges for products returned to any other locations.

This warranty shall not apply to any defect, failure or damage caused by improper use or improper or inadequate maintenance and care. Tektronix shall not be obligated to furnish service under this warranty a) to repair damage resulting from attempts by personnel other than Tektronix representatives to install, repair or service the product; b) to repair damage resulting from improper use or connection to incompatible equipment; c) to repair any damage or malfunction caused by the use of non-Tektronix supplies; or d) to service a product that has been modified or integrated with other products when the effect of such modification or integration increases the time or difficulty of servicing the product.

THIS WARRANTY IS GIVEN BY TEKTRONIX IN LIEU OF ANY OTHER WARRANTIES, EXPRESS OR IMPLIED. TEKTRONIX AND ITS VENDORS DISCLAIM ANY IMPLIED WARRANTIES OF MERCHANTABILITY OR FITNESS FOR A PARTICULAR PURPOSE. TEKTRONIX' RESPONSIBILITY TO REPAIR OR REPLACE DEFECTIVE PRODUCTS IS THE SOLE AND EXCLUSIVE REMEDY PROVIDED TO THE CUSTOMER FOR BREACH OF THIS WARRANTY. TEKTRONIX AND ITS VENDORS WILL NOT BE LIABLE FOR ANY INDIRECT, SPECIAL, INCIDENTAL, OR CONSEQUENTIAL DAMAGES IRRESPECTIVE OF WHETHER TEKTRONIX OR THE VENDOR HAS ADVANCE NOTICE OF THE POSSIBILITY OF SUCH DAMAGES.



Table of Contents

General Safety Summary	vii
Preface	ix
Contacting Tektronix	x

Getting Started

Product Description	1-1
Physical Dimensions	1-2
Accessories	1-2
Standard Accessories	1-2
Optional Accessories	1-2
Electrical Installation	1-4
AC Power Source	1-4
Changing the Mains Voltage	1-4
Power On Procedure	1-4
Mechanical Installation	1-6
Custom Installation	1-7
Rackmount Information	1-7
Functional Check	1-8

Operating Basics

Functional Overview	2-1
Front-Panel Features	2-1
Rear-Panel Connectors	2-3
Audio Output Connector	2-4
Differences Between DS1001A and DS1001G	2-5
Operating Procedures	2-7
Applying Power	2-7
Selecting Display Modes	2-8
System Status	2-8
Audio1 Output Status	2-9
Audio 2 Output Status	2-10
GCR Module Status	2-11
Program Set-up	2-12

Product Information	2-12
Firmware Revision	2-13
Locking/Unlocking the Front Panel	2-13
Temperature Status	2-14
Selecting a Program	2-14
Adjusting the Current Program	2-15

Reference

Configuring Operation	3-1
Quick Guide	3-2
Program Configuration	3-3
Config Program: Frequency Tables	3-4
Config Program: Channel	3-4
Config Program: Frequencies	3-5
Config Program: ZCP	3-5
Config Program: Signal Source	3-6
Config Program: Audio 1 Input Selection	3-7
Config Program: Audio 2 Input Selection	3-7
Config Program: AFC	3-7
Config Program: Sound Trap	3-8
Config Program: BTSC Stereo/SAP Noise Thresholds	3-8
GCR Module Configuration	3-9
Config GCR Module: CFH Interval	3-9
Config GCR Module: GCR Bypass	3-10
Serial Configuration	3-11
Config Serial: Serial Mode	3-11
Config Serial: Unit Address	3-11
Config Serial: RS232 RTS/CTS Status	3-12
Config Serial: RS485 Termination	3-12
Frequency Response Configuration	3-13
Contrast Adjustment	3-15
User Defined Channel Table	3-16

Appendices

Appendix A: Performance Specifications	A-1
Appendix B: Remote Control	B-1
Serial Port Connection	B-1
Programming Model	B-2

Addresses	B-3
Remote Operation Flag	B-4
Command Types	B-4
Sending and Receiving Data	B-5
Send Address Phase	B-5
Send Data Phase	B-6
Receive Address Phase	B-7
Polling for Status Messages	B-7
Getting a Message	B-9
Command Syntax	B-10
Data Types	B-10
Data Offset	B-11
Remote Command Descriptions	B-12
Appendix C: Service	C-1
Packaging for Shipment	C-1
Replacing the Fuse	C-2
Cleaning the Exterior	C-2
Appendix D: Channel Tables	D-1
Appendix E: Factory Default Settings	E-1

Glossary

Index

List of Figures

Figure 1-1: Rear-panel connectors	1-5
Figure 1-2: Typical system configuration	1-6
Figure 2-1: DS1001A/DS1001G front panel	2-1
Figure 2-2: DS1001A Rear-panel connectors	2-3
Figure 2-3: Audio output connector	2-4
Figure 2-4: DS1001G Rear-panel connectors	2-5
Figure B-1: Pin assignments for the SERIAL connector ...	B-2

List of Tables

Table 1-1: Power Cords	1-3
Table 3-1: Configure menu hierarchy	3-1
Table 3-2: Frequency response adjustment bands	3-14
Table A-1: Video specifications	A-1
Table A-2: Audio specifications	A-2
Table A-3: Electrical specifications - power requirements .	A-3
Table A-4: Environmental characteristics	A-3
Table A-5: Physical characteristics	A-3
Table A-6: Certifications and compliances	A-4
Table A-7: Safety certification and compliance	A-5
Table A-8: Safety standards	A-6
Table B-1: Rear-panel SERIAL port connections	B-2
Table B-2: Special byte codes	B-3
Table B-3: Data types used in remote communication	B-10
Table D-1: CATV HRC channel table	D-2
Table D-2: CATV IRC channel table	D-3
Table D-3: CATV standard channel table	D-5
Table D-4: Standard channel table	D-7
Table D-5: IRC channel table	D-9
Table D-6: HRC channel table	D-10
Table D-7: Broadcast channel table	D-12
Table E-1: Program default settings	E-1
Table E-2: System default settings	E-2

General Safety Summary

Review the following safety precautions to avoid injury and prevent damage to this product or any products connected to it. To avoid potential hazards, use this product only as specified.

Only qualified personnel should perform service procedures.

While using this product, you may need to access other parts of the system. Read the *General Safety Summary* in other system manuals for warnings and cautions related to operating the system.

To Avoid Fire or Personal Injury

Use Proper Power Cord. Use only the power cord specified for this product and certified for the country of use.

Connect and Disconnect Properly. Do not connect or disconnect probes or test leads while they are connected to a voltage source.

Ground the Product. This product is grounded through the grounding conductor of the power cord. To avoid electric shock, the grounding conductor must be connected to earth ground. Before making connections to the input or output terminals of the product, ensure that the product is properly grounded.

Observe All Terminal Ratings. To avoid fire or shock hazard, observe all ratings and markings on the product. Consult the product manual for further ratings information before making connections to the product.

Do Not Operate Without Covers. Do not operate this product with covers or panels removed.

Use Proper Fuse. Use only the fuse type and rating specified for this product.

Avoid Exposed Circuitry. Do not touch exposed connections and components when power is present.

Do Not Operate in Wet/Damp Conditions.

Do Not Operate in an Explosive Atmosphere.

Keep Product Surfaces Clean and Dry.

Provide Proper Ventilation. Refer to the manual's installation instructions for details on installing the product so it has proper ventilation.

Safety Terms and Symbols

Terms in This Manual. These terms may appear in this manual:



WARNING. *Warning statements identify conditions or practices that could result in injury or loss of life.*



CAUTION. *Caution statements identify conditions or practices that could result in damage to this product or other property.*

Terms on the Product. These terms may appear on the product:

DANGER indicates an injury hazard immediately accessible as you read the marking.

WARNING indicates an injury hazard not immediately accessible as you read the marking.

CAUTION indicates a hazard to property including the product.

Symbols on the Product. These symbols may appear on the product:



WARNING
High Voltage



Protective Ground
(Earth) Terminal



CAUTION
Refer to Manual

Preface

This is the user manual for the DS1001A/DS1001G Television Demodulator. The DS1001A/DS1001G model offers the following features:

- Simultaneous SAP and stereo audio outputs
- Dual composite video outputs
- Audio IF output
- IF input and output
- M/N Standard
- BTSC Stereo and SAP
- Dbx* Noise Reduction (*THAT Corporation)
- Front-panel lockout
- Ghost Cancellation (DS1001G only)

Topics covered in this manual are as follows:

- *Getting Started* includes a product description as well as installation and first-time power-on procedures.
- *Operating Basics* contains a functional overview, describing the front- and rear-panel controls and connectors and a tutorial, guiding the user through basic instrument operation.
- *Reference* contains details on setting up unit presets and descriptions of each preset item and its function.
- *Appendix A* provides instrument specifications, both electrical and mechanical.

Appendix B describes remote control interfaces, techniques, and the command set.

Appendix C describes changing fuses and cleaning the product.

Appendix D contains the channel tables used in the DS1001A.

Appendix E details the factory default settings.

Contacting Tektronix

Phone	1-800-833-9200*
Address	Tektronix, Inc. Department or name (if known) 14200 SW Karl Braun Drive P.O. Box 500 Beaverton, OR 97077 USA
Web site	www.tektronix.com
Sales support	1-800-833-9200, select option 1*
Service support	1-800-833-9200, select option 2*
Technical support	Email: techsupport@tektronix.com 1-800-833-9200, select option 3* 1-503-627-2400 6:00 a.m. - 5:00 p.m. Pacific time

* **This phone number is toll free in North America. After office hours, please leave a voice mail message. Outside North America, contact a Tektronix sales office or distributor; see the Tektronix web site for a list of offices.**



Getting Started

Getting Started

This section provides the information you need to use the television demodulator for the first time. Refer to the following sections to prepare the instrument for operation:

- *Product Description*
- *Options*
- *Electrical Installation*
- *Mechanical Installation*
- *Functional Check*

Product Description

The television demodulator can demodulate M/N standard television signals to baseband video and audio. In addition, the DS1001G provides the capability of recognizing a GCR signal and applying correction to the baseband video output. The DS1001A/DS1001G covers the tuning range of 55.25 to 801.25 MHz. The high performance of the conversion guarantees a measurement-quality signal after demodulation.

By applying an RF signal to the antenna input, the television demodulator provides baseband video and audio outputs and IF output signals.

You can set tuning conditions for stored programs, which are held in nonvolatile memory. Tune the signal by channel, frequency, or preset program. Twenty presets can be stored and recalled with different configurations.

Most instrument functions are controllable through the remote serial interface. Connection is through the SERIAL connector (9 pin) on the rear panel. The interface type, RS232C or RS485, is configured through the Serial Config menu. With the RS485 protocol, you can set unique addresses for multiple units and control them all remotely.

Physical Dimensions

The dimensions of the television demodulator are length 1.8 inches (46 mm), width 8.1 inches (206 mm), and depth 17.3 inches (440 mm). In a 19 inch (483 mm) rack, it is a half rack wide by one rack unit high.

Accessories

Standard Accessories

Your television demodulator includes the standard accessories listed below:

- DS1001A/DS1001G - Standard North American Power Cord (161-0066-00)
- Two, 250 V, 1.6 Amp (1.6AT) replacement fuses (159-0366-00)
- Audio output connectors (020-2381-00)
- User Manual (071-0905-01), this manual

Optional Accessories

You can order the following rackmounting kits from Tektronix:

- TVGF11A adapter mounts a single instrument in a standard 19-inch rack.
- TVGF13 adapter with air vents mounts two half-rack width instruments side-by-side in a standard 19-inch rack.
- TVGF14 adapter mounts two half-rack width instruments vertically in a standard 19-inch rack. Use this adapter to mount DS1001A and VM100 series instruments with a 1700 series monitor.

The following power cords can be ordered from Tektronix:

Table 1-1: Power Cords

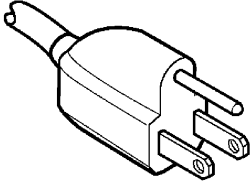
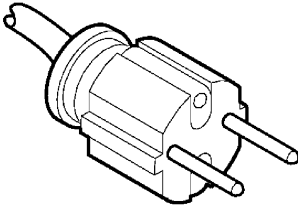
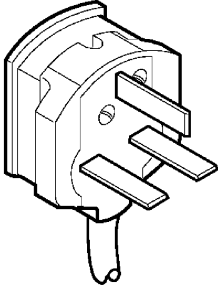
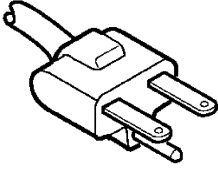
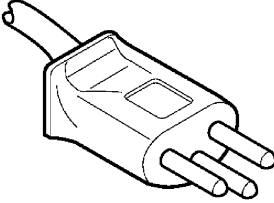
Plug configuration	Normal usage	Part number
	North America 115 V	Standard 161-0066-00
	Europe 230 V	161-0066-09
	United Kingdom 230 V	161-0066-10
	North America 230 V	161-0066-12
	Switzerland 230 V	161-0154-00

Electrical Installation

Before proceeding with product installation, please read the *Safety Summary* at the front of this manual.

NOTE. *Save the shipping carton and packing materials in case it becomes necessary to ship the television demodulator to a Tektronix Service Center for service or repair. Packaging instructions are on page C-1.*

AC Power Source

The television demodulator operates from an AC source with a line voltage in the range 100 to 240 VAC and with a line frequency of 50 or 60 Hz.

The television demodulator is designed to operate from a single-phase power source having one of its current-carrying conductors at or near earth ground (the neutral conductor). Only the line conductor is fused for over-current protection.

Systems that have both current-carrying conductors live with respect to ground (such as phase-to-phase on multiphase systems) are not recommended as power sources. A protective ground connection by way of the grounding conductor in the power cord is essential for safe operation.

Changing the Mains Voltage

The unit is designed to operate over the specified range (100 to 240 VAC) without the need for adjustment.

Power On Procedure

To power on the television demodulator, connect it to the AC power source. There is no power switch. See Figure 1-1. The power on sequence completes in about 10 seconds.

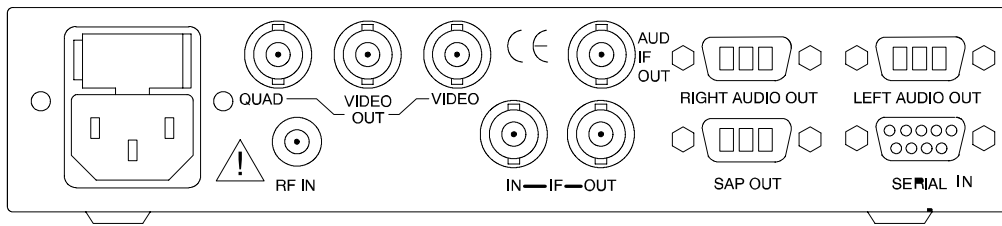

Figure 1-1: Rear-panel connectors

The television demodulator tests major circuits during power on and displays the following status messages:

ROM test

RAM test

I²C test

System Initialization

When testing completes, the television demodulator displays the current RF setting.

Mechanical Installation

The television demodulator requires no assembly. Please read the following sections before installing the television demodulator into a console or equipment rack. Figure 1-2 shows a sample connection in a system including a video monitor and an audio monitor.

NOTE. All qualification testing was performed with the factory-shipped cabinet installed. To guarantee compliance with specifications, operate the instrument only in the original cabinet.

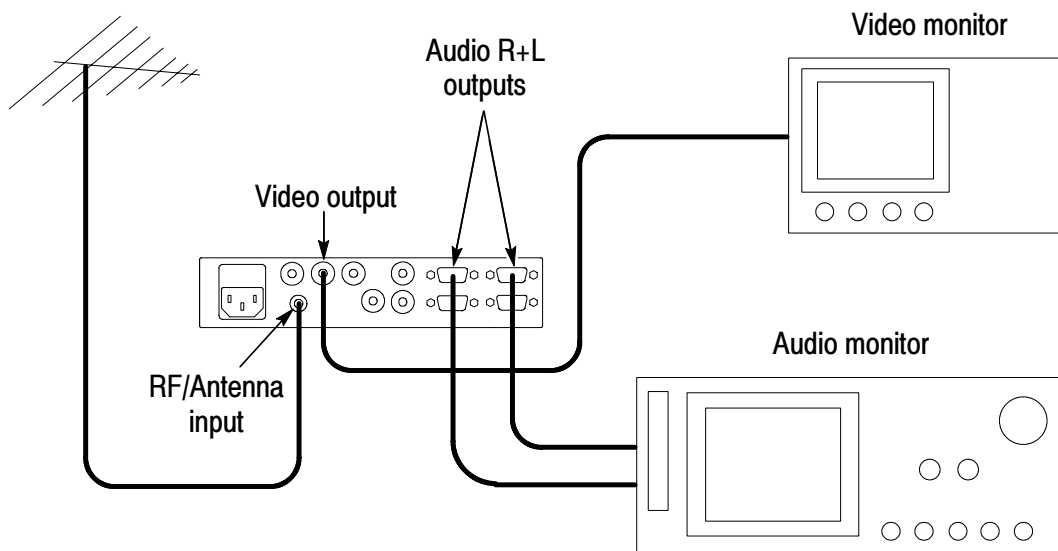

Figure 1-2: Typical system configuration

Custom Installation



CAUTION. *To avoid damage to the television demodulator, attach it to a shelf that is strong enough to hold its weight (5.0 lbs/2.3 kg).*

For applications that require installation into consoles, the television demodulator can be mounted with the front molding flush or protruding from the console. Always allow approximately 3 inches (7.6 cm) of rear panel clearance for cable and power cord connections.

Rackmount Information

The television demodulator is one half-rack wide and one rack unit high. It requires approximately 3 inches (7.6 cm) of rear panel clearance for the power cord and cable connections and 20 inches (50.8 cm) in front of the rack for installation and removal. See *Optional Accessories* on page 1-2 for available rackmount kits.

Functional Check

To check that the television demodulator is operating correctly, perform the following procedures:

1. Connect the television demodulator to power and wait a few seconds for the power-on tests and initialization. If these tests pass, the display will show the current frequency/channel setting.
2. Apply an RF signal feed from an appropriate television standard for your model of television demodulator to the RF input. Use a 75 Ω coaxial cable. The RF source should match the current frequency/channel setting. If not, refer to *Operating Basics* section for information on selecting a new frequency/channel.
3. Connect the video output(s) (VIDEO OUT-2 off) either to a picture monitor, waveform monitor, or other monitoring equipment. Ensure that this connection is terminated in 75 Ω .
4. Check for a valid video display and, if possible, a nominal 1 V_{pp} signal level.
5. Connect the audio outputs (RIGHT AUDIO OUT and LEFT AUDIO OUT) to a suitable audio monitoring device. For example, use the Lindos LA102 Audio Measuring Set. Check for a nominal 0 dBm level.
6. Connect the IF output (45.75 MHz vision carrier) to a 100 MHz oscilloscope terminated in 75 Ω .
7. Check for a nominal 1 V_{pp} (+51 dBmV) signal, measured at the sync tips.
8. Connect the AUD IF OUT to a 100 MHz oscilloscope terminated in 75 Ω .
9. Check for a nominal 900 mV_{pp} (+50 dBmV) signal.

This concludes the functional check. If your television demodulator failed any check in this procedure, review your connections, terminations, and instrument settings. A continued failure may indicate the need for repair. Contact your service person or a Tektronix, Inc. field office for assistance.



Operating Basics

Operating Basics

The DS1001A/DS1001G Television Demodulator is typically used as part of a system that includes video and audio measurement equipment, such as the Tektronix VM100 Series Automated Measurement Set. Typical equipment connections are described in the *Functional Check* procedure, located in section 1.

The television demodulator configuration system allows the store and recall of system settings through the use of programs (presets). All program settings are saved in the television demodulator nonvolatile memory when the unit is turned off.

The following procedures use factory settings for the illustrations; your display will vary if you change the settings.

Functional Overview

This section describes the front-panel and rear-panel features and connectors.

Front-Panel Features

This section describes the front panel controls, which are illustrated in Figure 2-1.

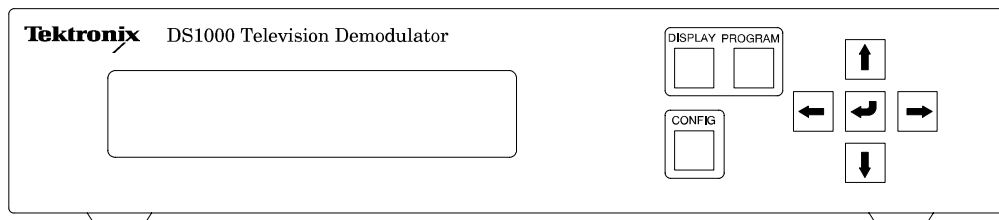

Figure 2-1: DS1001A/DS1001G front panel

- **Front Panel Display.** The two-line, 20-character liquid crystal display (LCD) is used to present unit configuration and status information.

The LCD uses “supertwist” technology allowing a wide viewing angle.

The LCD is illuminated with an LED back light, which enables its use in areas with low light levels.

The display contrast is adjustable in the Configure menu, as described on page 3-15 in the *Reference* section.

- **DISPLAY button.** Use the display button to step through the display modes. Each press of the button steps to the next display mode. When the last display mode is reached, the next press of the display button returns to the first display mode.
- **PROGRAM button.** Use the program button to enter the program selection mode.
- **CONFIG button.** Use the configuration button to modify settings.
- **UP and DOWN arrow buttons (↑ and ↓).** Use the up and down arrow buttons to scroll through the program set-up and program configuration items. When the unit status display is active, the up and down arrow buttons can be used to temporarily change the current channel number.
- **LEFT and RIGHT buttons (← and →).** Use the left and right arrow buttons to make changes to program configuration items. When the status display is active, the left and right arrow buttons can be used to temporarily change the current frequency.
- **ENTER button (↵).** Use the enter button to enter the required configuration mode and to accept configuration changes.

Rear-Panel Connectors

This section describes the rear-panel connectors of the DS1001A/DS100G, which are illustrated in Figures 2-2 and 2-4, respectively.

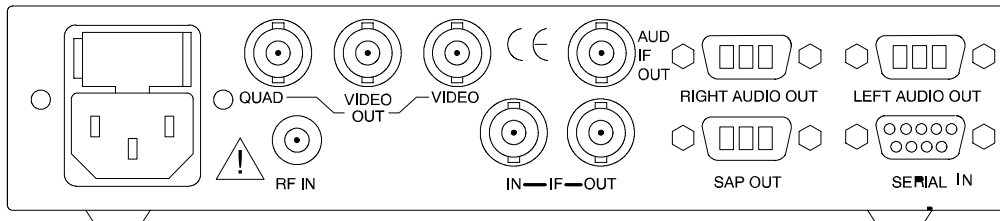

Figure 2-2: DS1001A Rear-panel connectors

- **Power Input Connector.** Accepts the AC power cord assembly that is shipped with the product.
- **Fuse Holder.** Provides a safety fuse for the AC mains input (100–240 V operation). The fuse holder is located just above the AC power connector. Refer to *Appendix C* for fuse replacement instructions.
- **Serial Connector.** Provides a bidirectional serial connection for remote control by a PC. The connector is a 9-pin, subminiature D-type. Serial communication using this connector complies with RS232 and RS485 standards. For instructions on selecting the RS232 or the RS485 interface, refer to *Serial Configuration* on page 3-11 in the *Reference* section. For remote control commands and techniques, refer to *Appendix B*.
- **QUAD O/P.** Provides a quadrature video output with nominal 75 Ω impedance.
- **VIDEO OUT.** Provides two video output connectors with a standard 1 volt output with nominal 75 Ω impedance.
- **AUDIO IF OUT.** Provides a buffered 4.5 MHz audio subcarrier output with nominal 75 Ω impedance.

- **IF IN.** Provides an IF signal with a nominal sensitivity of -24 dBm and a nominal 75 Ω impedance.
- **IF OUT.** Provides a buffered IF output (45.75 MHz vision carrier) of the full video vestigial side band with all sound carriers. The nominal impedance is 75 Ω . This output is available for re-modulation or monitoring (75 Ω terminated).
- **RF IN.** Provides RF signal input with a sensitivity of -20 to +20 dBmV and a nominal 75 Ω impedance.
- **RIGHT AUDIO OUT.** Provides a dbx noise-reduced BTSC stereo right channel, mono channel, or dbx noise-reduced BTSC SAP channel output.
- **LEFT AUDIO OUT.** Provides a dbx noise-reduced BTSC SAP channel output.
- **SAP OUT.** Provides a dbx noise-reduced BTSC second audio program (SAP) output or mono channel output.

Audio Output Connector

The following figure shows the wiring details of the audio output connectors located on the rear panel. Two types of mating connectors can be used with the audio output connectors, a shielded 3-way plug, or a cable housing.

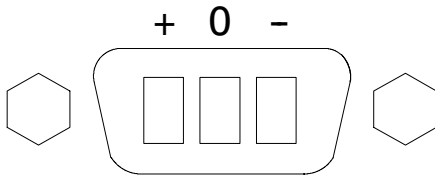

Figure 2-3: Audio output connector

Differences Between DS1001A and DS1001G

The main difference between the DS1001A and DS1001G television demodulators is a GCR (Ghost Canceller Reference) module replacing the DS1001A video output card.

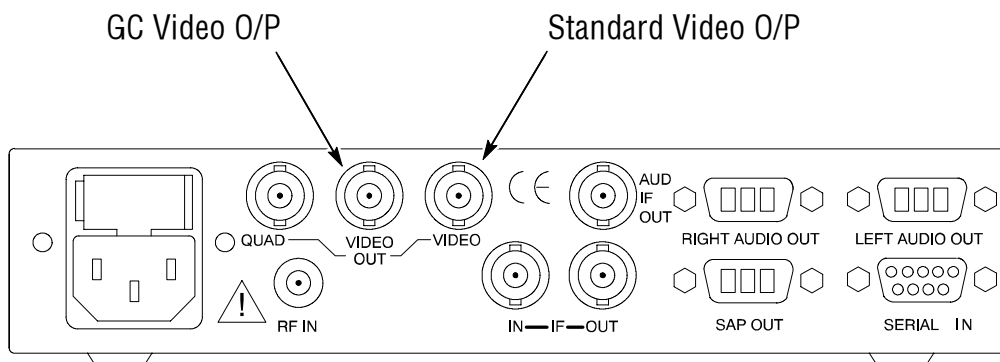

Figure 2-4: DS1001G Rear-panel connectors

The GCR module has three separate outputs located on the rear-panel, shown in Figure 2-4.

- **GC VIDEO O/P.** Video output providing a standard 1-volt output with nominal 75 Ω impedance. Can be switched to provide uncorrected video (identical to standard video O/P) or GCR corrected video (with 9 μ s delay).
- **STANDARD VIDEO O/P.** Video output providing a standard 1-volt output with nominal 75 Ω impedance.
- **QUAD O/P:** Same as DS1001A QUAD O/P.

The GCR module fitted in the DS1001G television demodulator replaces the video card found in the DS1001A. Two of the three outputs (QUAD O/P and STANDARD VIDEO O/P) match the outputs found on the DS1001A video card. The third output, which is a second STANDARD VIDEO O/P on the DS1001A video card, is a video output with the facility for reducing the effect of multi-path signal echoes (ghosts).

Software control of the GCR module allows the operator to select whether the video output from the GCR VIDEO O/P port has the ghost cancellation correction applied, or for the ghost cancellation circuit to be bypassed providing an uncorrected standard video signal on the output. For details on set-up of the GCR module, please refer to *GCR Module Configuration* on page 3-9.

The GCR module is comprised of a 576-tap internal digital filter, which cancels ghosts occurring from $-6.15\ \mu\text{s}$ before to $+41.6\ \mu\text{s}$ after the main signal. The digital filter is comprised a 144-tap finite impulse response (FIR) section that reduces precursor ghosts and a 432-tap recursive filter section that eliminates post-cursor ghosts. The 432-tap recursive filter section is further divided into a 360-tap main filter block that eliminates all post-cursor ghosts occurring from 0 to $+25\ \mu\text{s}$ after the main signal and two 36-tap “floating” filter blocks that remove rare ghosts occurring from $+25\ \mu\text{s}$ to $+41.6\ \mu\text{s}$ after the main signal. The DS1001G cancels ghosts with signal strength of $-6\ \text{dB}$ relative to the main video signal, leaving a ghost residue of less than $-35\ \text{dB}$ relative to the main signal.

The ghost cancellation algorithm is divided into three phases. In the first phase, the broadcast GCR is detected and sampled. The sampled GCR enables filter coefficient adaptation by the internal DSP unit in the second phase. Once the filter coefficients are calculated, cancellation is completed in the third phase by filtering the digitized video signal.

With GCR bypass mode turned off, the video input to the GCR module passes through the ghost cancellation circuit. With ghost cancellation active, the video signal on GC VIDEO O/P is delayed by approximately $9\ \mu\text{s}$ (when compared with the video signal on STANDARD VIDEO O/P).

With GCR bypass mode turned on, the video output signal on GC VIDEO O/P does not pass through the ghost cancellation circuit. This mode gives best video performance and provides matching video signals on GC VIDEO O/P and STANDARD VIDEO O/P.

To provide a stable output on the GCR VIDEO O/P port, the GCR module filter setting is frozen 5 s after a change of state has occurred (referred to as coefficient freeze). This change of state can be the result of either a user action or an automated update by the television demodulator. On detecting a change of state the television demodula-

tor unfreezes the filter allowing the GCR module to reapply the ghost cancellation algorithm to the input video signal.

The changes of state that cause the coefficients to unfreeze are:

- Power up
- Change of channel / frequency
- Pressing the enter button () in the GCR status display
- Automatically after a set interval
- Send remote command GC_CFH

The television demodulation freezes the coefficients 5 s after the change of state occurs and can only be unfrozen on the next change of state.

Operating Procedures

This section describes how to correctly apply power to the television demodulator and how to operate the instrument.

Applying Power

1. Apply an appropriate mains power source to the television demodulator through the supplied power cord. There is no power switch.
2. The front panel LCD briefly displays the starting self-test message before starting the self-tests. Each of the self-tests displays a different test message. If any of the tests fail, a test failure message appears and the unit waits for you to press a button before it continues with the remaining tests.

Once the self-tests complete, the unit initializes itself, which takes about 1 second to perform if the internal nonvolatile memory is valid.

If the memory has been corrupted or damaged, then the television demodulator will attempt to load factory default settings. This process takes 5 to 10 seconds. When the initialization sequence

completes, the unit displays the current channel/frequency selection along with the RF signal strength.

Selecting Display Modes

To access the display modes for the television demodulator, press the DISPLAY button on the front panel. To cycle through the modes, press the DISPLAY button repeatedly. The modes appear in the following order:

- System Status
- Audio 1 Output Status
- Audio 2 Output Status
- Program Set Up
- Product (information)
- Firmware (revision information)
- Front panel lock status
- Temperature Status

System Status

The system status display shows the input signal source (RF or IF) and signal level. If RF is the selected input source, the display shows the input signal level, the channel number and associated frequency.

```
RF LEVEL -----  
CH: 39 Fv:615.25MHz
```

If IF is the selected input source, the display shows the IF frequency.

```
RF LEVEL -----  
IF INPUT 45.75MHz
```

After power on sequence completes, the display shows the current channel and frequency selection and the RF signal strength for the channel and frequency.

The channel number is taken from the frequency table you select. It may be either numeric or alphanumeric depending on its definition in the frequency table.

If the frequency does not correspond to a channel frequency in the current frequency table, then the channel number is replaced by asterisks.

The RF signal strength is displayed in the form of a bar graph and represents the signal strength for the current channel frequency. A weak signal (RF amplitude < 100 μ V) is represented by 10 dashes ‘-’ on the bar graph. As the signal strength increases in amplitude, the dashes are replaced by blocks ‘■’ from the left, until all dashes have been replaced (RF amplitude > 1 mV).

Audio1 Output Status

The Audio 1 Output Status (Audio 1 O/P) shows the status of the audio signals on the Left Audio Out and Right Audio Out connectors located on the rear panel.



```
AUDIO 1  O/P STATUS  
AL:STEREO AR:STEREO
```

The status that shows depends on the audio mode that is selected and the audio modes available from the received signal. The following modes are available for Audio 1:

- Mono/SAP
- Stereo
- SAP

When you display the Audio 1 O/P Status, you can temporarily select audio modes using the right and left arrow buttons (← →) on the front panel. If all audio modes are available from the received signal,

the status display shows each mode. If a mode is not available on the received signal, the status display shows the following:

- If no Stereo, display shows:
Mono, Mono/SAP, Mono, SAP
- If no SAP, display shows:
Mono, Mono/Mute, Stereo, Mute
- If no Stereo or SAP, display shows:
Mono, Mono/Mute, Mono, Mute

To permanently change the audio mode, refer to the procedure in *Program Configuration* on page 3-3.

Audio 2 Output Status

The Audio 2 Output Status (Audio 2 O/P) shows the status of the audio signal on the SAP Out connector located on the rear panel.



```
AUDIO 2  O/P STATUS
SAP
```

The following modes can be selected for Audio 2:

- Mono
- SAP

When you display the Audio 2 O/P Status, you can select audio modes using the right and left arrow buttons (← →) on the front panel. If both audio modes are available from the received signal, the status display shows each mode.

If SAP is not available on the received signal, the status display shows the following:

Mono, Mute

GCR Module Status

DS1001G Only

The GCR Module Status (GCR Module) shows the status of the GCR module video signals located on the rear-panel. The various states shown depend upon the set-up of the GCR module and the content of the received video signal.

```
GCR MODULE  (NO GCR)
BYPASS ON   CFH OFF
```

GCR module bypass set on.
 GCR signal is not detected on line 19 of video signal.
 GCR coefficients not frozen.

```
GCR MODULE  (NO GCR)
BYPASS OFF  CFH OFF
```

GCR module bypass set off.
 GCR signal is not detected on line 19 of video signal.
 GCR coefficients not frozen.

```
GCR MODULE  (GCR)
BYPASS OFF  CFH OFF
```

GCR module bypass set off.
 GCR signal is detected on line 19 of video signal.
 GCR coefficients not frozen, ghost cancellation algorithm active.

```
GCR MODULE      (GCR)
BYPASS OFF      CFH ON
```

GCR module bypass set off.

GCR signal is detected on line 19 of video signal.

GCR coefficients frozen, ghost cancellation algorithm inactive.

In the GCR module status display mode, the GCR module coefficients can be manually unfrozen by pressing the enter button (↵). This allows the DS1001G to reapply the ghost cancellation algorithm to the current input video signal. After 5 s the coefficient freeze is automatically activated.

Program Set-up

The program set-up display allows you to view the configuration of the current program (preset). The top line shows the active program number and the bottom lines shows the program items. Use the up and down arrow buttons (↑ and ↓) to view the entire configuration by scrolling through the various program items. Refer to page 3-1 for a description of each item in the Program set up.

```
PROGRAM SET UP: 01
CH: 39 Fv:615.25MHz↓
```

To change a Program, select the Program number here, then press the CONFIG button. Refer to *Program Configuration* on page 3-3 for further instructions.

Product Information

The product information display shows the product number, transmission standard, and unit serial number.

```
PRODUCT: DS1001 (MN)
SERIAL No.: 00001234
```

Firmware Revision

The firmware revision display shows the firmware number and the revision number of firmware in the television demodulator. You will need this revision number when reporting problems in operation to Tektronix representatives.

```
FIRMWARE: FW0640  
REVISION: 04
```

Locking/Unlocking the Front Panel

You can lock the front panel to prevent accidental changes to the television demodulator setup. When the demodulator is powered up, the lock feature is active.

To unlock the front panel, complete the following steps:

1. Press the DISPLAY until the front panel lock status shows. The following message displays:

```
FRONT PANEL LOCKED  
PRESS DISPLAY KEY
```

2. Press the arrow buttons in the following sequence:



The following message displays:

```
FRONT PANEL UNLOCKED  
ENTER CODE TO LOCK
```

When the front panel is unlocked, the television demodulator settings can be adjusted.

To lock the front panel, follow steps 1 and 2 in the previous procedure.

Temperature Status

The temperature status display shows when the internal SAW filter reaches its normal operating temperature. The status is one of the following readouts:

- **LOW.** The television demodulator has not reached its normal operating temperature.
- **NORMAL.** The television demodulator has reached its normal operating temperature.
- **HIGH.** The television demodulator has exceeded its recommended operating temperature range.

```
UNIT TEMPERATURE  
STATUS: NORMAL
```

Selecting a Program

The television demodulator can store and recall 20 different programs (presets) from nonvolatile memory. Only one of the programs is active at a time. Use the PROGRAM button to select a program.

Pressing the PROGRAM button brings up the program selection display. The first line displays the current active program number and second line displays the program channel and frequency.

```
PROGRAM SELECT: 04 ↑  
CH: 39 Fv:615.25MHz↓
```

Use the up and down arrow buttons (↑ and ↓) to select from the 20 stored programs.

As each program number appears, its program configuration becomes active. When you reach the required program number, pressing the

display button exits the program selection mode. The selected program becomes the active program and will be recalled the next time you power on the unit.

Adjusting the Current Program

You can temporarily adjust the channel number and frequency while in the system status display. Use the up and down buttons (↑ and ↓) to change the channel and the left and right buttons to change the frequency. The changes you make are temporary and will be lost when you select another display mode or remove the AC power.



Reference

Reference

This section describes how to configure the television demodulator to fit your application.

Configuring Operation

The television demodulator has many configurable parameters which it stores in nonvolatile memory. Use the Configuration menu to select items. Table 3-1 lists the configurable items in the sequence that they appear.

Changes to program items immediately change the operation of the television demodulator. This active control allows you to see the affects of a change without exiting the program configuration mode. If selected changes do not give the desired result, you can discard the changes by exiting the configuration mode using the 'NO' save option.

Refer to *Appendix E* for a list of factory default settings for all configurable items.

Table 3-1: Configure menu hierarchy

	Configure menu	Selections	Range
1	Program	Frequency Table	UHF, VHF, user defined
		Channel	Various
		Frequency	NTSC: 55.25 to 801.25 MHz
		ZCP Status	On, Off
		ZCP Line Number	NTSC: 10-20 (F1 & F2)
		ZCP Position	0 to 4
		Signal Source	RF, IF

Table 3-1: Configure menu hierarchy (cont.)

	Configure menu	Selections	Range
		Audio 1 Input Select	Mono, Mono-SAP, Stereo, SAP
		Audio 2 Input Select	Mono, SAP
		AFC Status	On, Off
		Sound Trap	On, Off
		Stereo Noise	NTSC: 1-16
		SAP Noise	NTSC: 1-16
2	Frequency Response	Manual Frequency Response Adjust	-10 to +10
3	Contrast Adjust	Display Contrast Adjust	Dark to Max brightness
4	User Channel Table	Channel (1-50)	NTSC: 55.25 to 801.25 MHz
5	Serial Set-up	Serial Mode	RS232, RS485
		Unit Address	32 to 63
		RTS/CTS	Disabled, Enabled
		RS485 Termination	Unterminated, Terminated

Quick Guide

To configure the television demodulator, follow these procedures:

1. Press the front panel CONFIG button to access the Configuration menu.
2. Use the up and down arrow buttons (↑ and ↓) to select a configuration mode.
3. Press the enter button (↵) to enter the selected configuration mode.

4. Use the up and down arrow buttons (↑ and ↓) to select a configuration item. Use the left and right arrow buttons (← and →) to change the selected configuration item.
5. Press the CONFIG button after making the desired changes. If you have made no changes, then the Configuration menu returns. If you have made changes, then you are asked if you want to save the changes. Use the left and right arrow buttons (← and →) to select either yes or no, then press the enter button (↵).
6. To exit the configuration mode, press the DISPLAY button.

Program Configuration

The Program selection in the Configure menu allows you to modify a Program. Before entering the Configure menu, you must select the Program number you wish to modify.

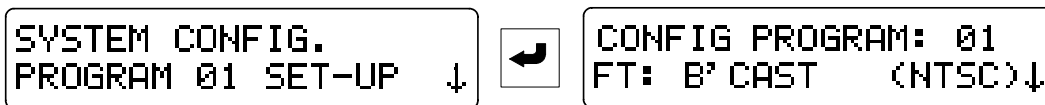

To modify a Program, press the Program button and use the up and down arrow buttons (↑ and ↓) to choose the program number you wish to modify. Then press the CONFIG button to access the Configuration menu. The top level selection is Program. Press the enter button (↵) to enter the Program Config menu. Use the up and down arrow buttons (↑ and ↓) to choose and change any of the following selections:

Config Program: Frequency Tables

The television demodulator contains a wide variety of frequency tables that list the channel assignments used in many countries. The channel assignments cover the standard television frequency spectrum.



You can select a frequency table using the FT item. Only one frequency table can be active for an individual program, but different programs can use different frequency tables. *Appendix D* includes a complete list of the frequency tables.

Config Program: Channel

Use the channel item (CH) to select a channel from the chosen frequency table. The channel frequency appears in brackets after the channel number. This channel selection and the following frequency selection interact. Changing either one will change the other.



Config Program: Frequencies

If the required frequency is not contained in any frequency table, you can manually set the frequency using the frequency item (Fv). The frequency range is 45.25 MHz to 860.25 MHz in 0.25 MHz steps.



If the selected frequency corresponds to a standard channel, then that channel number appears in parentheses. Otherwise, asterisks appear in place of the channel number. This frequency selection and the previous channel selection interact. Changing either one will change the other.

Config Program: ZCP

The zero carrier pulse (ZCP) is a special feature of the television demodulator. You configure the ZCP feature using the ZCP status, ZCP line, and ZCP position items.

The ZCP status item determines whether the ZCP signal is on or off.



The ZCP line setting determines on which video line the ZCP is active. For PAL systems the line number range is 6 - 16 and 319 - 329. For NTSC systems the line number range is 10 - 20 (F1) and 10 - 20 (F2).



The ZCP position item determines the start position of the ZCP on the chosen video line. The five position choices are 0 - 4.



Config Program: Signal Source

The Signal Source selection sets the input source to either RF or IF input. If the IF input source is selected, then the channel number and frequency settings become redundant and will not show on the system status display.



Config Program: Audio 1 Input Selection

The Audio 1 input selection allows control of the audio outputs (Left Audio Out and Right Audio Out) on the rear panel. The available choices are MONO, MONO/SAP, STEREO, and SAP.

```
CONFIG PROGRAM: 01 ↑  
AUDIO 1: STEREO ↓
```

Config Program: Audio 2 Input Selection

The Audio 2 input selection allows control of the audio output (SAP Out) on the rear panel. The choices are Mono and SAP.

```
CONFIG PROGRAM: 01 ↑  
AUDIO 2: SAP ↓
```

Config Program: AFC

The AFC selection, when enabled, sets the tuning system of the television demodulator to locate and lock to a frequency that drifts or to a frequency that is between the standard 0.25MHz frequency steps. The AFC function is not normally required for broadcast signals and should be used with caution because of its limited range of ± 1 MHz about the video carrier frequency.

```
CONFIG PROGRAM: 01 ↑  
AFC: OFF ↓
```

OFF ← ↑ → ON

The options for the AFC item are either on or off.

Config Program: Sound Trap

The sound trap status item when enabled adds extra filtering to remove any sound element from the video signal. The options for the sound trap item are either on or off.

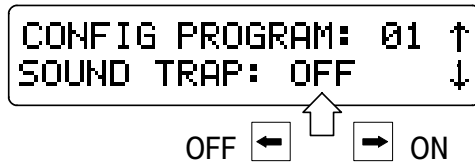

Config Program: BTSC Stereo/SAP Noise Thresholds

The BTSC Stereo and SAP noise threshold items are only present on NTSC systems and are used to switch stereo and SAP outputs off when the thresholds are reached. The range for both items is 1 - 16.



GCR Module Configuration

DS1001G Only

The GCR Module Set-up selection in the Configure menu, allows you to set up the ghost cancellation module parameters for the GC video port on the rear-panel.

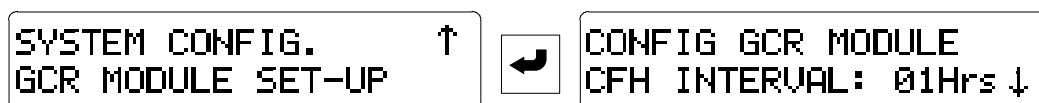

To modify the GCR module set-up, press the CONFIG button to access the Configure menu. Use the up and down buttons (↑ and ↓) to select GCR MODULE SET-UP. Press the enter button (↵) to enter the Config GCR module menu. Use the up and down buttons (↑ and ↓) to chose and change any of the selections.

Config GCR Module: CFH Interval

Sets the GCR module automatic coefficients unfreeze interval.

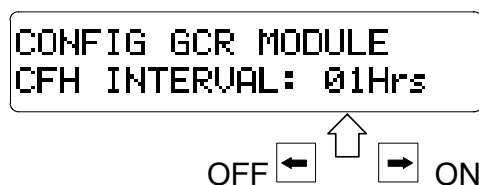

The CFH interval setting allows the DS1001G to periodically reapply the ghost cancellation algorithm to the current input video signal. After 5 s the coefficient freeze is automatically activated. The automatic unfreeze can be disabled by setting a value of 0, otherwise the interval can be set from 1 to 24 hours in hourly increments.

Config GCR Module: GCR Bypass

Sets the GCR module bypass control state.

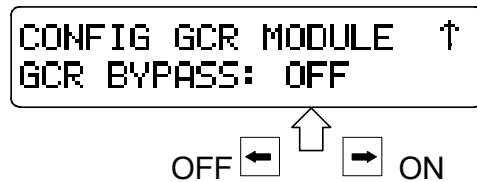

Setting the GCR module bypass to on causes the output on GC VIDEO O/P to match the output on STANDARD VIDEO O/P i.e. the GC video and standard video ports are supplied from the same video source, bypassing the ghost correction circuit.

Setting the GCR module bypass to off causes the output on the GC video port to pass through the ghost correction circuit.

The video signal on STANDARD VIDEO O/P is not affected by the GCR module bypass setting.

Serial Configuration

The Serial Set-up selection in the Configure menu, allows you to set the communications parameters of the serial port on the rear-panel.

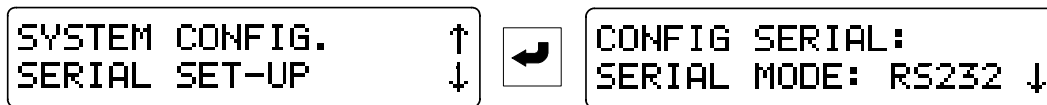

To modify the serial port setup, press the CONFIG button to access the Configure menu. Use the up and down buttons (↑ and ↓) to select SERIAL SET-UP. Press the enter button (↵) to enter the Config Serial menu. Use the up and down buttons (↑ and ↓) to choose and change any of the selections.

Config Serial: Serial Mode

Sets the mode of the serial port to either RS232 or RS485. Refer to *Appendix B* for connection information.

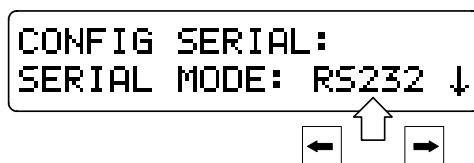

Config Serial: Unit Address

Sets the RS485 serial mode address. A controlling terminal or PC uses this address to identify and control a particular instrument.



The RS485 communications protocol allows connection of multiple units to one host. Each device connected to the host must have a unique address. The range for the unit address is 32 - 63.

Config Serial: RS232 RTS/CTS Status

Enables or disables hardware handshaking on the serial port when in the RS232 serial mode.

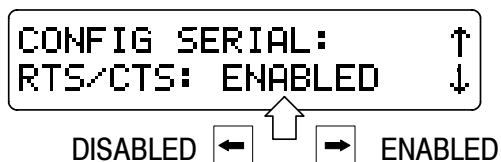

Config Serial: RS485 Termination

Enables or disables termination at the television demodulator in the RS485 serial mode. Enable termination when the television demodulator is the last device in a multi-drop system. Select unterminated when it is not the last device.



Frequency Response Configuration

In the television demodulator system there are two levels of frequency response adjustment. The first is factory set and cannot be adjusted from the front panel. The second is the manual frequency response item which allows minor adjustments to the frequency response.

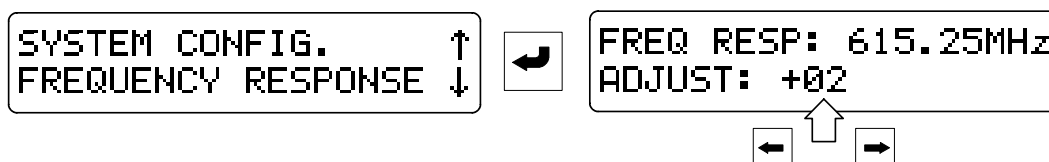

Use caution when changing the manual frequency response and do so only when connected to equipment that can measure the changes to frequency response.

The changes to frequency response affect only the current active frequency, which is shown on the top line of the frequency response configuration display. You can adjust several frequencies which are stored in the television demodulator non-volatile memory.

Due to memory limitations within the television demodulator, it is impractical to store frequency response adjustments for every possible frequency, so the adjustments are possible only for the range of frequencies listed in Table 3-2.

Table 3-2: Frequency response adjustment bands

Low band	Mid band	High band
40.00 - 47.75 MHz	170.00 - 179.75 MHz	454.25 - 469.75 MHz
48.00 - 55.75 MHz	180.00 - 189.75 MHz	470.00 - 489.75 MHz
56.00 - 63.75 MHz	190.00 - 199.75 MHz	490.00 - 509.75 MHz
64.00 - 71.75 MHz	200.00 - 209.75 MHz	510.00 - 529.75 MHz
72.00 - 79.75 MHz	210.00 - 219.75 MHz	530.00 - 549.75 MHz
80.00 - 87.75 MHz	220.00 - 229.75 MHz	550.00 - 569.75 MHz
88.00 - 95.75 MHz	230.00 - 239.75 MHz	570.00 - 589.75 MHz
96.00 - 103.75 MHz	240.00 - 249.75 MHz	590.00 - 609.75 MHz
104.00 - 111.75 MHz	250.00 - 259.75 MHz	610.00 - 629.75 MHz
112.00 - 119.75 MHz	260.00 - 269.75 MHz	630.00 - 649.75 MHz
120.00 - 127.75 MHz	270.00 - 279.75 MHz	650.00 - 669.75 MHz
128.00 - 135.75 MHz	280.00 - 289.75 MHz	670.00 - 689.75 MHz
136.00 - 143.75 MHz	290.00 - 299.75 MHz	690.00 - 709.75 MHz
144.00 - 151.75 MHz	300.00 - 309.75 MHz	710.00 - 729.75 MHz
152.00 - 159.75 MHz	310.00 - 319.75 MHz	730.00 - 749.75 MHz
160.00 - 162.75 MHz	320.00 - 329.75 MHz	750.00 - 769.75 MHz
163.00 - 167.75 MHz	330.00 - 339.75 MHz	770.00 - 789.75 MHz
168.00 - 169.75 MHz	340.00 - 349.75 MHz	790.00 - 809.75 MHz
	350.00 - 359.75 MHz	810.00 - 829.75 MHz
	360.00 - 369.75 MHz	830.00 - 849.75 MHz
	370.00 - 379.75 MHz	850.00 - 860.25 MHz
	380.00 - 389.75 MHz	
	390.00 - 399.75 MHz	
	400.00 - 409.75 MHz	

Table 3-2: Frequency response adjustment bands (cont.)

Low band	Mid band	High band
	410.00 - 419.75 MHz	
	420.00 - 429.75 MHz	
	430.00 - 439.75 MHz	
	440.00 - 454.00 MHz	

Contrast Adjustment

The Contrast Adjust selection in the Configure menu, allows you to set the contrast of the front-panel LCD display.

To modify the contrast, press the CONFIG button to access the Configure menu. Use the up and down buttons (↑ and ↓) to select Contrast Adjust. Press the enter button (↵) to enter the Contrast Adjustment menu.

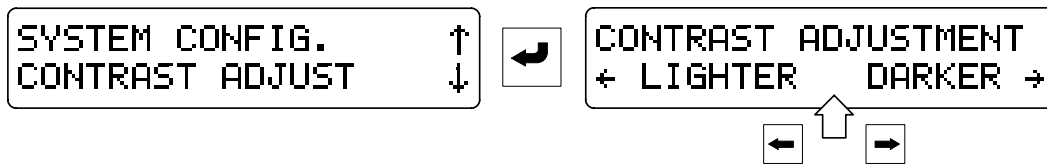

Use the left and right buttons (← and →) to set the contrast lower or higher as appropriate for the ambient light level. Press the enter button (↵) when you have finished.

User Defined Channel Table

The User Channel Table selection in the Configure menu, allows you to store several custom channel and frequency combinations in the User Channel Table.

To create or modify the User Channel Table, press the CONFIG button to access the Configure menu. Use the up and down arrow buttons (↑ and ↓) to select the User Channel Table. Press the enter button (↵) to enter the User Channel Table menu.

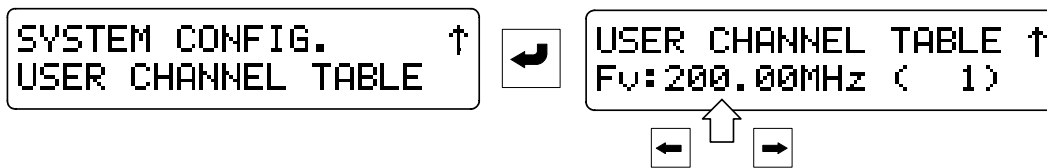

The television demodulator can store several custom channels and frequencies. You can select from channels 1 to 50 using the up and down arrow keys. Use the left and right arrow keys to set the new frequency for the channel. The channel frequency is saved when you either press the Config button or select another channel.

You select the User Defined channel table as you do other frequency and channel tables. Refer to *Program Configuration* on page 3-3 for instructions on selecting a frequency table.



Appendices

Appendix A: Performance Specifications

The instrument specifications listed in this section are either performance requirements or reference information.

Performance requirements, marked REQ, are valid over an ambient temperature range of 5°C to 35°C, unless otherwise noted. Ensure that test equipment used to verify performance requirements is calibrated and working within its specified limits.

Reference information, marked RI, amplifies a performance requirement or provides useful information on other operating parameters.

This section contains the following specifications:

- Table A-1 Video specifications
- Table A-2 Audio specifications
- Table A-3 Electrical specifications - power requirements
- Table A-4 Environmental characteristics
- Table A-5 Physical characteristics
- Table A-6 Certifications and compliances
- Table A-7 Safety certification compliance
- Table A-8 Safety standards

Table A-1: Video specifications

Category	Description
Tuning Range	55.25 - 801.25 MHz M/N
IF Frequency	45.75 MHz M/N
Sensitivity	-20 dBmV to +20 dBmV (Recommended 0 - 30 dBmV)
Return Loss	> 6 dB, worst case over frequency range
Input Impedance	75 Ω , F type connector

Table A-1: Video specifications (cont.)

Category	Description
Frequency Stability	±50 kHz
Signal to Noise	> 50 dB weighted
Two Video Outputs	1 Vpp on BNC connectors (On DS1001G only - GCR processing on single BNC as indicated)
One Quadrature Output	On BNC connector
Differential Gain	< 1.5% (< 2.5% DS1001G typical)
Differential Phase	±1.5° (± 2° DS1001G typical)
Chroma/Luma Delay	< 40 ns
Frequency Response	±0.7 dB: 100 kHz - 3.8 MHz M/N ±0.7 dB: 100 kHz - 4.6 MHz B/G, I, D/K
Group Delay Characteristic	100 kHz to 3.58 MHz ± 50 ns (35 ns typical) M/N 100 kHz to 4.43 MHz ± 60 ns (35 ns typical) B/G, I
Luminance Bar Amp	< 2%
Luminance Bar Tilt	< 2% typical 1%
2T K Factor	< 2.5%, typical, RI: Input level at 20 dBmV
Baseline Distortion	< 2% typical

Table A-2: Audio specifications

Category	Description
BTSC Stereo for NTSC	
Connectors	Special DIN
Frequency Response	50 Hz to 12 kHz, ±0.5 dB typical (28 Hz -14.8 kHz, -3 dB points typical)
Total Harmonic Distortion	< 1%
Level	0 dBm across 600 Ω

Table A-3: Electrical specifications - power requirements

Category	Description
Line Voltage Ranges	100 to 240 VAC \pm 10%
Power Consumption	35 W Maximum
Line Frequency	50/60 Hz
Fuse	1.6AT, 250 V (20 mm ceramic)

Table A-4: Environmental characteristics

Category	Description
Operating Temperature	5° C to 35° C
Storing Temperature	-20° C to 70° C
Operating Altitude	6500 feet maximum (2.0 km)

Table A-5: Physical characteristics

Category	Description
Dimensions	Height: 1.8 inches (46 mm) Width: 8.1 inches (206 mm) Depth: 17.3 inches (440 mm)
Weight	Net Weight: 4.8 pounds (2.2 kg)

Table A-6: Certifications and compliances

Category	Description
<p>EC Declaration of Conformity - EMC</p>	<p>Meets intent of Directive 89/336/EEC for Electromagnetic Compatibility. Compliance was demonstrated to the following specifications as listed in the Official Journal of the European Communities:</p> <p>EN 55103:¹ Product family standard for audio, video, audio-visual and entertainment lighting control apparatus for professional use</p> <p>Environment E2 - Commercial and light industrial (rack-mounted)</p> <p>Part 1 Emissions EN 55022 Class B radiated and conducted emissions EN 55103-1, Annex A Radiated magnetic field emissions EN 55103-1, Annex B Inrush current EN 61000-3-2 AC Power line harmonic emissions</p> <p>Part 2 Immunity IEC 61000-4-2 Electrostatic discharge immunity IEC 61000-4-3 RF Electromagnetic field immunity IEC 61000-4-4 Electrical fast transient/burst immunity IEC 61000-4-5 Power line surge immunity IEC 61000-4-6 Conducted RF immunity IEC 61000-4-11 Voltage dips and interruptions immunity EN 55103-2, Annex A Radiated magnetic field immunity EN 55103-2, Annex B Balanced ports common mode immunity</p>
<p>USA FCC Compliance - EMC</p>	<p>Emissions comply with FCC Code of Federal Regulations 47, Part 15, Subpart B, Class A Limits¹</p>
<p>EC Declaration of Conformity - Low Voltage</p>	<p>Compliance was demonstrated to the following specification as listed in the Official Journal of the European Communities:</p> <p>Low Voltage Directive 73/23/EEC, Amended by 93/68/EEC</p> <p>EN 61010-1/A2:1995 Safety requirements for electrical equipment for measurement, control, and laboratory use</p>
<p>Installation Category Descriptions</p>	<p>Terminals on this product may have different installation category designations. The installation categories are:</p>

Table A-6: Certifications and compliances (cont.)

Category	Description
	CAT III Distribution-level mains (usually permanently connected). Equipment at this level is typically in a fixed industrial location
	CAT II Local-level mains (wall sockets). Equipment at this level includes appliances, portable tools, and similar products. Equipment is usually cord-connected
	CAT I Secondary (signal level) or battery operated circuits of electronic equipment

¹ Compliance demonstrated using high-quality, shielded cables.

Table A-7: Safety certification and compliance

Category	Description
Temperature (operating)	+5° C to +35° C
Altitude (maximum operating)	2000 meters
Relative Humidity (maximum operating)	80% for temperatures up to 31° C, decreasing linearly to 50% at 35° C
Equipment Type	Test and Measuring
Safety Class	Class I (as defined in IEC 1010-1, Annex H) - grounded product
Overvoltage Category	Overvoltage category II (as defined in IEC 1010-1, Annex J)
Pollution Degree	Pollution Degree 2 (as defined in IEC 1010-1) Note: Rated for indoor use only.

Table A-8: Safety standards

Category	Description
U.S. Nationally Recognized Testing Laboratory Listing (ETL)	UL3111-1 - Standard for Electrical Measuring and Test Equipment
Canadian Certification (ETL)	CAN/CSA C22.2 No. 1010.1 - Safety Requirements for Electrical Equipment for Measurement, Control, and Laboratory Use.
European Union Compliance	Low Voltage Directive 73/23/EEC, Amended by 93/68/EEC EN61010-1/A2 - Safety Requirements for Electrical Equipment for Measurement, Control, and Laboratory Use.
Additional Compliance	IEC1010-1/A2 - Safety Requirements for Electrical Equipment for Measurement, Control, and Laboratory Use. ISA S82.02.01-1999 - Safety Standard for Electrical and Electronic Test, Measuring, Controlling, and Related Equipment

Appendix B: Remote Control

This appendix describes how to remotely control the television demodulator. This appendix provides the following information:

- Serial port connection
- Programming model
- Command syntax descriptions
- Alphabetical list of commands

Serial Port Connection



CAUTION. *Connecting or disconnecting cables while the television demodulator is powered on can result in damage to its input circuits.*

The rear panel SERIAL connector allows remote control of the television demodulator using a PC controller. The connector is a 9-pin, subminiature D-type with female contacts. Table B-1 and Figure B-1 give the pin configuration for the SERIAL connector.

The SERIAL connector provides a configurable serial communications port. You can configure the serial port as either RS232 or RS485 using the Serial Configuration menu. Refer to page 3-11.

Before initiating remote control of the television demodulator, set the PC serial port as follows:

Speed: 9600 bps

Protocol: 1 start bit, 8 data bits, no parity, 1 stop bit

Interface: RS485 or RS232 (match the television demodulator setting)

Handshaking: RS232 only, use RTS/CTS hardware handshaking (match the television demodulator setting)

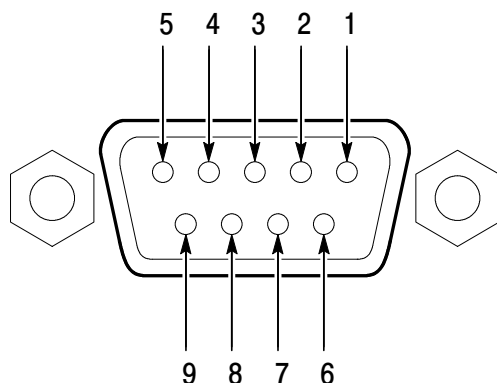

Figure B-1: Pin assignments for the SERIAL connector

Table B-1: Rear-panel SERIAL port connections

Pin	Function	Pin	Function
1	RS485 B	6	Not Used
2	RS232 TxD	7	RS232 CTS
3	RS232 RxD	8	RS232 RTS
4	Not Used	9	RS485 A
5	Signal Ground		

Programming Model

The television demodulator uses the BCP Simplified Communication Link protocol (SCL). With the SCL Protocol, you program a PC to send and receive data using standard I/O functions found in most programming languages, such as C, PASCAL, and BASIC.

The SCL protocol supports asynchronous binary communication, not text or ASCII based. Communication is based on 8-bit bytes ranging from 0 to 255. Table B-2 lists special byte codes used to coordinate data transfers between the PC and the television demodulator. For information on how to use these special byte codes, refer to *Sending and Receiving Data* on page B-5.

Table B-2: Special byte codes

Code mnemonic	ASCII	Description	Control characters
STX	02 hex	Start of data	^B
ETX	03 hex	End of data	^C
ENQ	05 hex	Enquiry	^E
DLE	10 hex	Data link escape	^P
ACKO	11 hex	Device is ready	^Q
WACK	3B hex	Device is not ready	;
Ad	0F hex	Device address	^O
Ar	*	User-defined remote address	
Ars	Ar x 2	Send remote address	
Arr	Ar x 2 + 1	Receive remote address	

* **You assign the remote address. For more information, refer to *Addresses* on page B-3.**

Addresses

The television demodulator has four addresses that are necessary for communication using the SCL protocol. Table B-2 lists the four addresses: Ad, Ar, Ars, and Arr. For information on using these addresses, refer to page B-5. The addresses perform the following functions:

- Device address (Ad) is set to 0F hex in all television demodulators. The PC uses the device address to initiate communication with a television demodulator.
- Remote address (Ar) is unique for each television demodulator. You set this unique address as a decimal number. To set the address, use the SERIAL SET-UP item in the configuration menu. The remote address is the base address used to determine the Ars and Arr addresses.

- Send remote address (Ars) is used to send data to the television demodulator. Calculate Ars using the following equation:

$$\text{Ars} = \text{Ar} \times 2$$

- Receive remote address (Arr) is used to receive data from the television demodulator. Calculate Arr using the following equation:

$$\text{Arr} = \text{Ar} \times 2 + 1$$

For example, if you set the remote address (Ar) to 50 decimal (32 hex), its SCL protocol addresses are as follows:

Ad (from Table B-2) = 0F hex

Ars = (32 hex) x 2 = 64 hex

Arr = (32 hex) x 2 + 1 = 65 hex

Remote Operation Flag

Some commands can be used only when the television demodulator is in the remote controlled state. When in remote control state, you cannot control the television demodulator from the front panel. The front panel display indicates the remote control state with the message “REMOTE CONTROLLED”

Two commands control the state of the remote flag. Use the command PWD= to enter the remote control state and set the remote flag to true (1). Use the DISC= command to resume front panel control and set the remote flag to false (0). Use the LOG? query to get the current state of the remote flag.

Command Types

There are two types of commands.

- Select commands end with an an equal sign (=), such as “PRESET=". Select commands set the television demodulator to operate in any mode allowed from the front panel.
- Query commands end with a question mark (?), such as “PRESET?". Query commands tell the television demodulator to prepare to send a particular type of data to the PC.

Commands may be followed by one or more parameters specific to the command. Parameters are in binary format. Query commands often do

not require parameters. The response data from a query command may contain several parameters.

For information on the syntax used for command definitions, refer to page B-11. The alphabetical list of commands and their parameters begins on page B-13.

Sending and Receiving Data

The PC must send commands and addresses in a certain order when writing data to and reading data from the television demodulator. The main steps in the communications process are as follows:

1. Send the identifying addresses.
2. Detect readiness of the television demodulator.
3. Send command and parameters.
4. Receive response/data.

Several types of communications are possible. Each type has a pattern of commands or phases that must be used. The following discussions introduce these communication phases: send address, send data, receive address, poll for messages, and get messages.

Send Address Phase

The PC uses Ad and Ars to address a particular television demodulator. The television demodulator configured with a matching address answers with either a ready response or a not ready response. Sending this address data aborts all other communication on the bus. The following three cases show variations of the send address phase.

The PC addresses a television demodulator that is not ready to receive data:

```
PC > [DLE] [ENQ] [Ad] [Ars]    Addressing phase  
DS1000 > [DLE] [WACK]         Not ready response
```

The PC addresses a television demodulator that is ready, and the PC sends data:

```
PC > [DLE] [ENQ] [Ad] [Ars]    Addressing phase
```

DS1000 > [DLE] [ACK0] [Ad] [Ars] *Ready response*

PC > [DLE] [STX] [Data] [DLE] [ETX] *Data phase*

The PC addresses a television demodulator that is not ready, ignores the not ready response, and sends data:

PC > [DLE] [ENQ] [Ad] [Ars] *Addressing phase*

DS1000 > [DLE] *Aborted ready response*

PC > [DLE] [STX] [Data] [DLE] [ETX] *Data phase*

The PC can ignore the not-ready response and transmit the addressing phase and data phase sequentially. In this case, the television demodulator aborts the not ready response after receiving the first byte of the data phase. The PC receives only a DLE character.

When sending data, Ad and Ars can be replaced by FF hex, a broadcast address. When the television demodulator sends a ready response, it will send its real address. You can use this broadcast address to determine the address of a television demodulator. The wild card remote address is always a send address phase.

Send Data Phase

The send data phase begins with a command and may be followed by one or more parameters specific to the command. Two techniques for sending data are possible.

The PC addresses a television demodulator that is ready and sends data:

PC > [DLE] [ENQ] [Ad] [Ars] *Addressing phase*

DS1000 > [DLE] [ACK0] [Ad] [Ars] *Ready response*

PC > [DLE] [STX] [Data] [DLE] [ETX] *Data phase*

The PC addresses a television demodulator that is not ready, ignores the not ready response, and sends data:

PC > [DLE] [ENQ] [Ad] [Ars] *Addressing phase*

DS1000 > [DLE] *Aborted ready response*

PC > [DLE] [STX] [Data] [DLE] [ETX] *Data phase*

The PC can ignore the not-ready response and transmit the addressing phase and data phase sequentially. In this case, the television demodulator aborts the not ready response after receiving the first byte of the data phase. The PC receives only a DLE character.

If the byte 10 hex is part of the data, this byte is sent twice so that it is not confused with DLE ETX (10 hex), which ends the data phase.

Receive Address Phase

To acquire data from the television demodulator, the PC first sends the Ad and Arr addresses to identify the television demodulator. This address phase aborts other communication on the same bus. The television demodulator responds with a not ready phase if it does not have the requested data. It responds with a ready phase followed by a data phase when it has data. The receive data phase contains the Ad and Arr addresses to identify the responding television demodulator.

Examples of receive communication between the PC and the television demodulator follows with descriptions in italics.

The PC addresses a television demodulator that has no data available:

```
PC > [DLE] [ENQ] [Ad] [Arr]    Addressing phase
DS1000 > [DLE] [WACK]         Not Ready response
```

The PC addresses a television demodulator that has data available, and the television demodulator returns the data:

```
PC > [DLE] [ENQ] [Ad] [Arr]    Addressing phase
DS1000 > [DLE] [STX] [Ad] [Arr] [Data] [DLE] [ETX]
                                           Ready response and data phase
```

If the byte 10 hex is part of the data, this byte is sent twice so that it is not confused with DLE ETX (10 hex), which ends the data phase.

Polling for Status Messages

If a television demodulator has a message, it does not send it to the PC, because more than one television demodulator can be connected to the same remote interface bus. To avoid data contention, the PC uses polling to check for messages.

Polling is done with the PATH? command. PATH? returns an empty string if the television demodulator has no message, and returns the

path if a message is available. The path contains the addresses Ad and Ars (see *Addresses* on page B-3).

The following example is one continuous polling communication between the PC and the television demodulator. The values for Ad, Ars, and Arr can be calculated according to instructions on page B-3.

The PC addresses a television demodulator that is busy, repeats the addressing phase until the television demodulator returns a ready phase, then the PC sends the "PATH?" command.

```
PC > [DLE] [ENQ] [Ad] [Ars] Send Addressing phase
DS1000 > [DLE] [WACK] Not Ready response
PC > [DLE] [ENQ] [Ad] [Ars] Send Addressing phase
DS1000 > [DLE] [ACK0] [Ad] [Ars] Ready response
PC > [DLE] [STX] [' PATH?' ] [DLE] [ETX] Data phase
```

After receiving the PATH? command, the television demodulator places its answer in its transmit buffer. The PC tries to retrieve the message with a receive cycle, but the television demodulator has not processed the answer yet.

```
PC > [DLE] [ENQ] [Ad] [Arr] Receive Addressing phase
DS1000 > [DLE] [WACK] Not Ready phase
```

The PC repeats the addressing phase until the television demodulator is ready and transmits its data phase. There is no data included, because the television demodulator has no message.

```
PC > [DLE] [ENQ] [Ad] [Arr] Receive Addressing phase
DS1000 > [DLE] [STX] [Ad] [Arr] [DLE] [ETX] Data phase
```

The PC continuously polls the television demodulator.

```
PC > [DLE] [ENQ] [Ad] [Ars] Send Addressing phase
DS1000 > [DLE] [ACK0] [Ad] [Ars] Ready phase
PC > [DLE] [STX] [' PATH?' ] [DLE] [ETX] Data phase
```

PC > [DLE] [ENQ] [Ad] [Arr] *Receive Addressing phase*

The television demodulator responds with data when it has a message. The [data] is the path, Ad Ars, which indicates that a message is available from the responding television demodulator.

DS1000 >[DLE] [STX] [Ad] [Arr] [data] [DLE]
[ETX]

Data phase

Getting a Message

Polling a television demodulator only tells the PC if a message is available. To receive the message, you must use the MSG? command.

The following example shows how to use the MSG? command to retrieve a status message from a television demodulator.

The PC addresses a television demodulator that is busy and repeats the addressing phase until the television demodulator returns a ready phase. The PC then sends the “MSG?” command.

PC >[DLE] [ENQ] [Ad] [Ars] *Send Addressing phase*

DS1000 > [DLE] [ACK0] [Ad] [Ars] *Ready phase*

PC > [DLE] [STX] ['MSG?'] [DLE] [ETX] *Data phase*

After receiving the MSG? command, the television demodulator places its answer in its transmit buffer, and the PC retrieves the message with a receive phase. The data in this example (20h) is the test message. Other bit patterns are listed with the MSG? command.

PC > [DLE] [ENQ] [Ad] [Arr] *Receiving addressing phase*

DS1000 > [DLE] [STX] [Ad] [Arr] [20h] [DLE]
[ETX]

Data phase

The PC acknowledges the data by sending the MSG= command followed by the data bit pattern. The PC resumes polling, but clears the message data as it reads the message.

PC > [DLE] [ENQ] [Ad] [Ars] *Send addressing phase*

DS1000 > [DLE] [ACK0] [Ad] [Ars] *Ready phase*

PC > [DLE] [STX] ['MSG='] [20h] [DLE] [ETX]
Data phase

Command Syntax

The command descriptions follow a consistent format. The elements of that format are discussed here.

Description. Gives the function of the command, conditions of its use, and its interactions with other commands.

Syntax. Gives the valid select and query command forms. The required arguments are listed in their proper order.

For example, in the syntax definition

```
PATH= <Ad><Ars>
```

the arguments <Ad> and <Ars> are required in the order indicated.

Arguments. The arguments to a command are defined along with their range of values.

Returns. Defines the data returned in response to a command query.

Data Types

Data sent with a command or received from a query may be of the types listed in Table B-3.

Table B-3: Data types used in remote communication

Data type	Description
byte	8 bits, ordered highest to lowest (b7, b6, b5, b4, b3, b2, b1, b0).
word	16 bits, sent as 2 bytes, with the MSB first.
character (char)	Transferred as a single byte, representing an ASCII character. Char(10) would indicate a string containing 10 characters, such as 'ABCDEFGHIJ'.
Boolean	0 or 1, representing an off or on state.
bitmap	A string of bits with a definite length, where each bit represents the state of a parameter.

Data Offset

The offset is the relative position of a data item in the transmitted or received data. The first bit in a data transfer is number 1, so the first byte has an offset of 1.

Remote Command Descriptions

The following remote commands appear in alphabetical order.

AFC

Sets or requests the current AFC status. The television demodulator must be in the remote state to use this command.

Syntax

AFC=
AFC?

Arguments

<afc_state> Either 0 for off or 1 for on.

Examples

Command	Result
'AFC=' 1	AFC control is set to on.

AUD_OUT

Selects or requests the audio output mode for the Left Audio Out and Right Audio Out channels. The television demodulator must be in the remote state to use this command.

Syntax

AUD_OUT= <aud_val>
 AUD_OUT? <aud_status>

Arguments

Argument	Format	Description		
<aud_val>	byte	Value	Left	Right
		0:	Mono	Mono
		1:	Mono	SAP
		2:	Stereo (L)	Stereo (R)
		3:	SAP	SAP
<aud_status>	byte	Value	Left	Right
		0:	Mute	Mute
		1:	Reserved	
		2:	Reserved	
		3:	Reserved	
		4:	Stereo (L)	Stereo (R)
		5:	SAP	SAP
		6:	Mono	Mono
		7:	Mono	SAP
8:	Mono	Mute		

Examples

Command	Result
' AUD_OUT=' 2	Audio output mode set to stereo
' AUD_OUT=?' '	' 7' Left Audio Out is MONO Right Audio Out is SAP

The 'AUD_OUT=' command sets the television demodulator audio mode for the primary BTSC decoder (Left Audio Out and Right Audio Out). The audio mode options for the primary BTSC decoder are MONO, MONO / SAP, STEREO, and SAP. Setting a particular audio mode does not necessarily mean that the audio output matches the selected mode because the audio output is dependent upon the audio content of the received transmission.

Example 1

If STEREO mode is selected but the transmission contains only MONO, then the output on Left Audio Out and Right Audio Out is MONO. If the transmission changes to STEREO, Left Audio Out and Right Audio Out also change to STEREO.

Example 2

If MONO mode is selected and the transmission is also MONO, then Left Audio Out and Right Audio Out will be MONO. If the transmission changes to STEREO, Left Audio Out and Right Audio Out will remain in MONO.

NOTE. *This command is valid for all models of the television demodulator (DS1001, DS1001A, and DS1001G).*

AUD_PREF

Sets or requests the output mode for the SAP OUT channel. The television demodulator must be in the remote state to use this command.

Syntax

AUD_PREF= <aud_val>
 AUD_PREF? <aud_status>

Arguments

Argument	Format	Description																
<aud_val>	byte	<table border="0"> <tr> <td>Value</td> <td>SAP Out</td> </tr> <tr> <td>0:</td> <td>Mono</td> </tr> <tr> <td>1:</td> <td>SAP</td> </tr> </table>	Value	SAP Out	0:	Mono	1:	SAP										
Value	SAP Out																	
0:	Mono																	
1:	SAP																	
<aud_status>	byte	<table border="0"> <tr> <td>Value</td> <td>SAP Out</td> </tr> <tr> <td>0:</td> <td>Mute</td> </tr> <tr> <td>1:</td> <td>Reserved</td> </tr> <tr> <td>2:</td> <td>Reserved</td> </tr> <tr> <td>3:</td> <td>Reserved</td> </tr> <tr> <td>4:</td> <td>Reserved</td> </tr> <tr> <td>5:</td> <td>SAP</td> </tr> <tr> <td>6:</td> <td>Mono</td> </tr> </table>	Value	SAP Out	0:	Mute	1:	Reserved	2:	Reserved	3:	Reserved	4:	Reserved	5:	SAP	6:	Mono
Value	SAP Out																	
0:	Mute																	
1:	Reserved																	
2:	Reserved																	
3:	Reserved																	
4:	Reserved																	
5:	SAP																	
6:	Mono																	

Examples

Command	Result
' AUD_PREF= ' 1	Audio output mode is set to SAP for SAP Out channel
' AUD_PREF? '	'0' SAP Out is MONO

The ' AUD_PREF=' command sets the television demodulator audio mode for the secondary BTSC decoder (SAP Out). The audio mode options for the secondary BTSC decoder are MONO and SAP. Setting a particular audio mode does not necessarily mean that the audio

output matches the selected mode because the audio output is dependent upon the audio content of the received transmission.

Example

If SAP mode is selected but the transmission does not contain SAP, then SAP Out is MUTE. If the transmission changes to SAP, SAP Out changes to SAP.

NOTE. *This command is valid only for the DS1001A and DS1001G television demodulators. Although this command is not valid for the DS1001, it will not have any adverse affect on its operation.*

BTSC

Sets or requests the stereo and SAP noise threshold for the BTSC controller. The television demodulator must be in the remote state to use this command.

Syntax

BTSC= <stnt_val><sapnt_val>
 BTSC?

Arguments

Byte offset	Argument	Format	Description
1	<stnt_val>	byte	Sets the stereo noise threshold in the BTSC controller. Range is 0 to 15.
2	<sapnt_val>	byte	Sets the SAP noise threshold in the BTSC controller. Range is 0 to 15

Examples

Command	Result
' BTSC=' 10 7	BTSC stereo noise threshold set to level 10. BTSC SAP noise threshold set to level 7.

CHANNEL

Sets or requests the selected channel record number and frequency table of the television demodulator. Sending the CHANNEL= command automatically sets the tuning mode to CHANNEL. The television demodulator must be in the remote state to use this command. For the query command, set TUNING to mode 0.

Syntax

CHANNEL=<table><channel_rec>
CHANNEL?

Arguments

Byte offset	Argument	Description
1	<table>	Selects the table of channels from one of the following: 0: User defined table 1: CATV HRC 2: CATV IRC 3: CATV STD 4: STDOFST 5: IRC 6: HRC 7: B'CAST
2	<channel_rec>	Selects the record number in the selected table. The table record number corresponds to a particular channel number. Refer to <i>Appendix D</i> for the record number associated with each channel number in the selected table.

Examples

Command	Result
' CHANNEL=' 1 18	Table 1, CATV HRC frequency table. is selected. Channel record 18 selected = channel number 19

DISC

Puts the television demodulator in the local state, which enables the front panel controls and clears the remote flag. Use the command PWD to enter the remote state and set the remote flag.

Syntax

DISC=

Arguments

none

FREQ

Sets or requests the demodulation frequency. Setting the frequency automatically sets the tuning mode to FREQ TUNE. See the command description for TUNING. The television demodulator must be in the remote state to use this command.

Syntax

FREQ= <freqH_val><freqL_val>
FREQ?

Arguments

Byte offset	Argument	Format	Description
1	<freqH_val>	word: [x yyy]	Sets the integer part of the frequency in MHz. X = frequency in MHz/256. YYY = frequency in MHz - (x * 256). The range is 45 to 860.
3	<freqL_val>	word: [x yyy]	Sets the fractional part of the frequency in kHz. X = frequency in kHz/256. YYY = frequency in kHz - (x * 256). The range is 0 to 999.

Examples

Command	Result
' FREQ=' [1 100 0 250]	freqH: [1 100] = 1x256+100 = 356 MHz freqL: [0 250] = 250 kHz The frequency set is 356.25 MHz.

GC_CFH

DS1001G Only

Sets or requests the GCR module coefficients hold state. The set command unfreezes the coefficients hold, enabling the ghost cancellation algorithm to be reapplied to the current input video signal. After 5 s the coefficients hold is automatically activated. The get command returns the current coefficients hold state.

The television demodulator must be in the remote state to use this command.

Syntax

```
GC_CFH=  
GC_CFH? <gc_cfh_state>
```

Arguments

<gc_cfh_state> is either 0 for on (coefficients unfrozen) or 1 for on (coefficients frozen).

Examples

Command	Result
' GC_CFH='	GC module coefficients are unfrozen.
' GC_CFH?'	1 GC module coefficients are frozen.

GC_BYP

DS1001G Only

Sets or requests the bypass control state for the GC video output on the GCR module. The effect of this command is to bypass the ghost cancellation circuit, with the GC VIDEO O/P and STANDARD VIDEO O/P ports having matching signals.

The television demodulator must be in the remote state to use this command.

Syntax

```
GC_BYP= <bypass_state>
GC_BYP?
```

Arguments

<bypass_state> is either 0 for or 1 for RF input.

Examples

Command	Result
' GC_BYP=' 1	GCR module bypass is set to on i.e. GC VIDEO O/P set to match STANDARD VIDEO O/P.
' GC_BYP?'	0 GCR module bypass control state is off.

GC_DET (Query only)

DS1001G Only

Requests the ghost cancellation detection state on the GCR module. The ghost cancellation detection state indicates if the GCR signal on line 19 of the video is present.

Syntax

GC_DET? <gcr_detect>

Arguments

<gc_detect> is either 0 for GCR signal not detected or 1 for GCR signal detected.

Examples

Command	Result
' GC_DET?'	1 GCR signal detected.

GC_INT

Sets or requests the GC module interval for automatically unfreezing the coefficients. This allows the DS1001G to periodically reapply the ghost cancellation algorithm to the current input video signal. After 5 s the coefficients hold is automatically activated. The automatic unfreeze can be disabled by setting a value of 0, otherwise the interval can be set from 1 to 24 hours in hourly increments.

The television demodulator must be in the remote state to use this command.

Syntax

```
GC_INT= <gcr_interval>
GC_INT?
```

Arguments

<gcr_interval> is the unfreeze coefficient interval. Range 0-24 where 0 is disabled and 1-24 is interval in hours.

Examples

Command	Result
'GC_INT=' 1	GCR module automatic coefficients unfreeze interval set to 1 hour.
'GC_INT?'	0 GCR module automatic coefficients unfreeze is disabled.

IDN

Sets or requests the television demodulator identification. The query returns the device name ('DS1001A') followed by the software version number ('V01.00'), and a defined name <unit_loc>. You can assign a device name with IDN= <unit_loc>. The television demodulator must be in the remote state to use this command.

Syntax

```
IDN= <unit_loc>
IDN?<device> <version><unit_loc>
```

Arguments

<unit_loc> up to 20 characters
 <device> <version><unit_loc>

Returns

Byte offset	Argument	Format	Description
1	<device>	Char(10)	Model ('DS1001A')
11	<version>	Char(6)	Software version ('V01.00')
17	<unit_loc>	Char(20)	Custom name ('DEM0D2')

Examples

Command	Result
' IDN?'	' DS001A V01.00' ' DEM0D2' The model is DS1001A, the software is version 1.00 and the custom name is DEM0D2.

LOG? (Query only)

Requests the remote state of the television demodulator. Use the command **PWD** to start remote operation and **DISC** to return to local operation.

Syntax

LOG?

Arguments

<remote flag> 0 for local control, 1 for remote

Returns

<remote flag>

Examples

```
' LOG?'
```

```
0
```

The television demodulator is in the local state.

MSG

Clears or requests the status of the television demodulator. The MSG? command causes the television demodulator to place any messages in its transmit buffer. Use a receive phase to return the message. The television demodulator can be polled continuously; see page B-7.

MSG= clears the message bit(s) matching the true bits in the message byte <state>. The television demodulator must be in the remote state to use the MSG= command.

Syntax

MSG=<state>
MSG?

Arguments

<state> is 1h to FFh. FFh clears all message bits.

Returns

Bitmap of <state>	Description of True state (1)
b7: Invalid remote command	Television demodulator received an invalid command
b6: Wrong remote parameter	Television demodulator received the wrong parameter
b0 - b5: Not used	

Examples

'MSG?'
128 decimal
which equals 80h or 10000000b. This message indicates an invalid command.

MSG_C

Enables or disables message generation in the television demodulator. Setting MSG_C from 1 to 0 clears all pending messages. The television demodulator must be in the remote state to use this command.

Syntax

```
MSG_C= <msg_state>  
MSG_C?
```

Arguments

<msg_state> one byte, either 1 to enable messages or 0 to disable them.

Examples

Command	Result
'MSG_C=' 1	The television demodulator may now generate messages.

PATH

Polls the television demodulator to check for status messages. The television demodulator returns its <Ad><Ars> addresses when there is a message and a null string when there are no messages. Use the MSG? command to get the actual status message. If the messages are disabled with the MSG_C command, the television demodulator will not have a message.

For more information on using the PATH command for polling, refer to page B-7.

Syntax

PATH= <Ad><Ars>
 PATH?

Returns

Device address	Description
<Ad>	Device address, always [0F hex] for the television demodulator.
<Ars>	Remote address, calculated on page B-3.

Examples

Command	Result
' PATH?'	<Ad><Ars> The television demodulator has a message and is ready to send it. The <Ad><Ars> addresses are contained in the <data> returned.

PRESET

Sets or requests the settings for one of the 20 programs without affecting the present operation of the television demodulator. Use the RECPRT command to activate a preset program number. The television demodulator must be in the remote state to use this command.

Syntax

PRESET=<pres_nr><settings_data>
PRESET?

Arguments

<pres_nr> is the program number to set or query. Range 1-20.
<settings_data> Refer to the SETT command for a definition of these parameters.

Examples

Command	Result
' PRESET?'	<settings_data>
10	Returns the program data for number 10.

PWD

Puts the television demodulator in the remote state and sets the remote flag. The front panel is disabled when in the remote state. Use the command DISC to enter the local state and clear the remote flag.

Syntax

PWD=

Arguments

none

RECPRT

Selects and makes active the current program (preset) or requests the current number. The data in <prog_nr> becomes the current setting of the television demodulator. This command sets the tuning mode to PROGRAM. This command is allowed only when the remote flag is true and when TUNING = 4, indicating the PROGRAM mode.

Syntax

RECPRT= <prog_nr>
RECPRT?

Arguments

<prog_nr> one byte in the range 1 to 20 to indicate the program number.

Examples

Command	Result
' RECPRT?'	12 The program number 12 is the current active program.

REPORT? (Query only)

Requests the operating state of the television demodulator. The response is 0 when an active input signal is detected and 2 when no signal is detected. The television demodulator must be in the remote state to use this command.

Syntax

REPORT? <tic_state>

Arguments

<tic_state> one byte, either 0 to indicate an active signal, or 2 to indicate no input signal.

Examples

Command	Result
' REPORT?'	2 The television demodulator does not detect a signal.

SETT

Sets or requests several operating parameters of the television demodulator. With the SETT command, you can set several parameters at once instead of using several different commands. SETT can replace the following commands: **FREQ**, **AFC**, **AUD_PREF**, **STRAP**, **ZCP**, **BTSC** and **AUD_OUT**. The new settings are effective immediately. The television demodulator must be in the remote state to use this command.

Syntax

```
SETT=<settings_data>
SETT?
```

Arguments

<setting_data>

Byte offset	Setting	Range	Command/desc
1-2	freqH_val	55 to 800	FREQ
3-4	freqL_val	0 to 999	FREQ
5	status_flags	bitmap status byte	Set the bit true (1) to enable the associated function: b7: Source select b6: ZCP control b5: Audio 1 mode select bit 1 b4: Audio 1 mode select bit 0 b3: Audio 2 mode select b2: Sound trap control b1: AFC control b0: Off-channel frequency
	Source select, bit 7:		
	b7	Mode	
	0	IF Input	
	1	RF Input	

Byte offset	Setting	Range	Command/desc
	Audio 1 mode, bits 4&5:		
	b4 b5 Mode		
	0 0 Mono		
	1 0 Mono/SAP		
	0 1 Stereo		
	1 1 SAP		
	Audio 2 mode, bit 3:		
	b3 Mode		
	0 Mono		
	1 SAP		
6-7	ZCP line number	0 to 21	ZCP
8	ZCP position	0 to 4	ZCP
9	BTSC stereo noise	0 to 15	BTSC
10	BTSC SAP noise	0 to 15	BTSC

Examples

Command	Result
'SETT?'	Returns the current settings of the television demodulator.

SIGLEV? (Query Only)

Requests the nominal level of the signal received by the television demodulator. The response is 0 when no signal is detected, or a value between 1 and 10, where 1 indicates a weak signal and 10 indicates a strong signal. The television demodulator must be in the remote state to use this command.

Syntax

SIGLEV?<sig_level>

Arguments

<sig_level> one byte in the range 0 - 10 to indicate the nominal received signal strength, where:

- 0 = No signal received
- 1 = Weak signal
- 10 = Strong signal

Examples

Command	Result
'SI GLEV?'	10 The television demodulator is receiving a strong signal.

SOURCE

Sets or requests the input source selection. The television demodulator must be in the remote state to use this command.

Syntax

```
SOURCE=<ip_srce>  
SOURCE?
```

Arguments

<ip_srce> is either 0 or IF input or 1 for RF input.

Examples

Command	Result
' SOURCE=' 1	Input source is set to RF.

STRAP

Sets or requests the status of the sound trap. The television demodulator must be in the remote state to use this command.

Syntax

```
STRAP= <strap_state>  
STRAP?
```

Arguments

<strap_state> Either 1 for On or 0 for Off.

Examples

Command	Result
' STRAP=' 1	Sound trap is on.

TUNING

Sets or requests the tuning mode. The tuning mode can be by channel, frequency, or from a programmed (preset) setting. The television demodulator must be in the remote state to use this command.

Syntax

TUNING=<tune_mode>
TUNING?

Arguments

<tune_mode> may be set to any of three modes:

- 0, Channel tuning, allows tuning by channel number.
- 3, Frequency tuning, allows tuning by frequency in network standard increments.
- 4, Programmed tuning, allows tuning by loading a stored preset.

Examples

Command	Result
' TUNING?'	4: Returned data of [4] means television demodulator is in program (preset) mode.

ZCP

Sets or requests the status of the zero carrier pulse (ZCP). The television demodulator must be in the remote state to use this command.

Syntax

ZCP= <zcp_state><zcp_line_no><zcp_position>
ZCP?

Arguments

Byte offset	Arguments	Range						
1	<zcp_state>	0 for Off, 1 for On						
2-3	<zcp_line_no>	Sets the line number on which the ZCP is activated. The range is 0 to 20. The <zcp_line_no> translates to an actual video line number as follows: <table border="1" data-bbox="771 1113 1383 1239"> <thead> <tr> <th>Line No.</th> <th></th> </tr> </thead> <tbody> <tr> <td>0-10:</td> <td>10-20 (Field 1)</td> </tr> <tr> <td>11-21:</td> <td>10-20 (Field 2)</td> </tr> </tbody> </table>	Line No.		0-10:	10-20 (Field 1)	11-21:	10-20 (Field 2)
Line No.								
0-10:	10-20 (Field 1)							
11-21:	10-20 (Field 2)							
4	<zcp_position>	ZCP position on the selected line. Range is 0 to 4.						

Examples

Command	Result
' ZCP=' 1 13 1	ZCP is active on line 12 (field 2) in position 1.

Appendix C: Service



WARNING. *To avoid personal injury or damage to the unit, be sure that the power is **not** supplied to the television demodulator while performing the procedures in this section.*

This section contains instructions for user service and preventative maintenance. The only serviceable part is the fuse, which is available on the rear panel.

There are no user serviceable parts within the unit. Please return it to a Tektronix Service Center for service and calibration.

Packaging for Shipment

If it becomes necessary to ship the television demodulator to a Tektronix Service Center, follow these instructions:

1. Write the following on a tag attached to the product: the product owner, complete address and phone number of someone at your firm who can be contacted, the product serial number and a description of the required service.
2. Package the product in the original packaging materials. If they are not available, follow these directions:
 - a. Obtain a carton of corrugated cardboard having inside dimensions at least 6 in (150 mm) greater than the dimensions of the instrument.
 - b. Surround the product with a protective bag (anti-static preferred).
 - c. Pack dunnage or urethane foam between the product and the carton. If you use Styrofoam kernels, overfill the box and compress by closing the lid. There should be 3 in (75 mm) of tightly packed cushioning on all sides of the instrument.
3. Seal the carton with shipping tape, an industrial stapler, or both.

Replacing the Fuse

1. Disconnect the power cable from the television demodulator rear panel.
2. Remove the fuse holder by inserting a suitable instrument on either side of the holder and pulling straight out.
3. Remove the old fuse and replace it with a new fuse of the same type. Use only 250 V, 1.6 A time-delayed fuses.
4. Replace the fuse holder ensuring that the holder clicks back into its socket.

Cleaning the Exterior

The instrument should be cleaned often enough to prevent dust and dirt from accumulating. Dirt acts as a thermal insulator, preventing effective heat dissipation and providing high-resistance electrical leakage paths between conductors or components in a humid environment.



CAUTION. *To avoid damaging the unit, do not allow water to get inside any enclosed assembly or component. Do not clean any plastic materials with benzene, toluene, xylene, acetone, or similar solvents, because they may damage the plastic.*

Clean the dust from the outside of the instrument with a soft, dry cloth or small brush. A brush is especially useful for removing dust from around the buttons and connectors.

Appendix D: Channel Tables

This section contains the frequency and channel tables used by the television demodulator system. When manually selecting a channel, the television demodulator displays the channel name and number. When selecting a channel using the remote serial commands, the channel record number provides access to the channels.

Table	Name	Standard	Channels	Page
D-1	CATV HRC channel table	NTSC	99	D-2
D-2	CATV IRC channel table	NTSC	98	D-3
D-3	CATV standard channel table	NTSC	124	D-5
D-4	Standard channel table	NTSC	124	D-7
D-5	IRC channel table	NTSC	99	D-9
D-6	HRC channel table	NTSC	99	D-10
D-7	Broadcast channel table	NTSC	68	D-12

Table D-1: CATV HRC channel table

Rec no.	Chan no.	Freq (MHz)	Rec no.	Chan no.	Freq (MHz)	Rec no.	Chan no.	Freq (MHz)
0	1	72.00	25	26	234.00	50	51	384.00
1	2	54.00	26	27	240.00	51	52	390.00
2	3	60.00	27	28	246.00	52	53	396.00
3	4	66.00	28	29	252.00	53	54	402.00
4	5	78.00	29	30	258.00	54	55	408.00
5	6	84.00	30	31	264.00	55	56	414.00
6	7	174.00	31	32	270.00	56	57	420.00
7	8	180.00	32	33	276.00	57	58	426.00
8	9	186.00	33	34	282.00	58	59	432.00
9	10	192.00	34	35	288.00	59	60	438.00
10	11	198.00	35	36	294.00	60	61	444.00
11	12	204.00	36	37	300.00	61	62	450.00
12	13	210.00	37	38	306.00	62	63	456.00
13	14	120.00	38	39	312.00	63	64	462.00
14	15	126.00	39	40	318.00	64	65	468.00
15	16	132.00	40	41	324.00	65	66	474.00
16	17	138.00	41	42	330.00	66	67	480.00
17	18	144.00	42	43	336.00	67	68	486.00
18	19	150.00	43	44	342.00	68	69	492.00
19	20	156.00	44	45	348.00	69	70	498.00
20	21	162.00	45	46	354.00	70	71	504.00
21	22	168.00	46	47	360.00	71	72	510.00
22	23	216.00	47	48	366.00	72	73	516.00
23	24	222.00	48	49	372.00	73	74	522.00
24	25	228.00	49	50	378.00	74	75	528.00

Table D-1: CATV HRC channel table (cont.)

Rec no.	Chan no.	Freq (MHz)	Rec no.	Chan no.	Freq (MHz)	Rec no.	Chan no.	Freq (MHz)
75	76	534.00	83	84	582.00	91	92	630.00
76	77	540.00	84	85	588.00	92	93	636.00
77	78	546.00	85	86	594.00	93	94	642.00
78	79	552.00	86	87	600.00	94	95	90.00
79	80	558.00	87	88	606.00	95	96	96.00
80	81	564.00	88	89	612.00	96	97	102.00
81	82	570.00	89	90	618.00	97	98	108.00
82	83	576.00	90	91	624.00	98	99	114.00

Table D-2: CATV IRC channel table

Rec no.	Chan no.	Freq (MHz)	Rec no.	Chan no.	Freq (MHz)	Rec no.	Chan no.	Freq (MHz)
0	2	55.25	12	14	121.25	24	26	235.25
1	3	61.25	13	15	127.25	25	27	241.25
2	4	67.25	14	16	133.25	26	28	247.25
3	5	79.25	15	17	139.25	27	29	253.25
4	6	85.25	16	18	145.25	28	30	259.25
5	7	175.25	17	19	151.25	29	31	265.25
6	8	181.25	18	20	157.25	30	32	271.25
7	9	187.25	19	21	163.25	31	33	277.25
8	10	193.25	20	22	169.25	32	34	283.25
9	11	199.25	21	23	217.25	33	35	289.25
10	12	205.25	22	24	223.25	34	36	295.25
11	13	211.25	23	25	229.25	35	37	301.25

Table D-2: CATV IRC channel table (cont.)

Rec no.	Chan no.	Freq (MHz)	Rec no.	Chan no.	Freq (MHz)	Rec no.	Chan no.	Freq (MHz)
36	38	307.25	57	59	433.25	78	80	559.25
37	39	313.25	58	60	439.25	79	81	565.25
38	40	319.25	59	61	445.25	80	82	571.25
39	41	325.25	60	62	451.25	81	83	577.25
40	42	331.25	61	63	457.25	82	84	583.25
41	43	337.25	62	64	463.25	83	85	589.25
42	44	343.25	63	65	469.25	84	86	595.25
43	45	349.25	64	66	475.25	85	87	601.25
44	46	355.25	65	67	481.25	86	88	607.25
45	47	361.25	66	68	487.25	87	89	613.25
46	48	367.25	67	69	493.25	88	90	619.25
47	49	373.25	68	70	499.25	89	91	625.25
48	50	379.25	69	71	505.25	90	92	631.25
49	51	385.25	70	72	511.25	91	93	637.25
50	52	391.25	71	73	517.25	92	94	643.25
51	53	397.25	72	74	523.25	93	95	91.25
52	54	403.25	73	75	529.25	94	96	97.25
53	55	409.25	74	76	535.25	95	97	103.25
54	56	415.25	75	77	541.25	96	98	109.25
55	57	421.25	76	78	547.25	97	99	115.25
56	58	427.25	77	79	553.25			

Table D-3: CATV standard channel table

Rec no.	Chan no.	Freq (MHz)	Rec no.	Chan no.	Freq (MHz)	Rec no.	Chan no.	Freq (MHz)
0	2	55.25	25	27	241.25	50	52	391.25
1	3	61.25	26	28	247.25	51	53	397.25
2	4	67.25	27	29	253.25	52	54	403.25
3	5	77.25	28	30	259.25	53	55	409.25
4	6	83.25	29	31	265.25	54	56	415.25
5	7	175.25	30	32	271.25	55	57	421.25
6	8	181.25	31	33	277.25	56	58	427.25
7	9	187.25	32	34	283.25	57	59	433.25
8	10	193.25	33	35	289.25	58	60	439.25
9	11	199.25	34	36	295.25	59	61	445.25
10	12	205.25	35	37	301.25	60	62	451.25
11	13	211.25	36	38	307.25	61	63	457.25
12	14	121.25	37	39	313.25	62	64	463.25
13	15	127.25	38	40	319.25	63	65	469.25
14	16	133.25	39	41	325.25	64	66	475.25
15	17	139.25	40	42	331.25	65	67	481.25
16	18	145.25	41	43	337.25	66	68	487.25
17	19	151.25	42	44	343.25	67	69	493.25
18	20	157.25	43	45	349.25	68	70	499.25
19	21	163.25	44	46	355.25	69	71	505.25
20	22	169.25	45	47	361.25	70	72	511.25
21	23	217.25	46	48	367.25	71	73	517.25
22	24	223.25	47	49	373.25	72	74	523.25
23	25	229.25	48	50	379.25	73	75	529.25
24	26	235.25	49	51	385.25	74	76	535.25

Table D-3: CATV standard channel table (cont.)

Rec no.	Chan no.	Freq (MHz)	Rec no.	Chan no.	Freq (MHz)	Rec no.	Chan no.	Freq (MHz)
75	77	541.25	92	94	643.25	109	111	715.25
76	78	547.25	93	95	91.25	110	112	721.25
77	79	553.25	94	96	97.25	111	113	727.25
78	80	559.25	95	97	103.25	112	114	733.25
79	81	565.25	96	98	109.25	113	115	739.25
80	82	571.25	97	99	115.25	114	116	745.25
81	83	577.25	98	100	649.25	115	117	751.25
82	84	583.25	99	101	655.25	116	118	757.25
83	85	589.25	100	102	661.25	117	119	763.25
84	86	595.25	101	103	667.25	118	120	769.25
85	87	601.25	102	104	673.25	119	121	775.25
86	88	607.25	103	105	679.25	120	122	781.25
87	89	613.25	104	106	685.25	121	123	787.25
88	90	619.25	105	107	691.25	122	124	793.25
89	91	625.25	106	108	697.25	123	125	799.25
90	92	631.25	107	109	703.25			
91	93	637.25	108	110	709.25			

Table D-4: Standard channel table

Rec no.	Chan no.	Freq (MHz)	Rec no.	Chan no.	Freq (MHz)	Rec no.	Chan no.	Freq (MHz)
0	2	55.25	25	13	211.25	50	47	361.26
1	3	61.25	26	23	217.25	51	48	367.26
2	4	67.25	27	24	223.25	52	49	373.26
3	5	77.25	28	25	229.26	53	50	379.26
4	6	83.25	29	26	235.26	54	51	385.26
5	95	91.25	30	27	241.26	55	52	391.26
6	96	97.25	31	28	247.26	56	53	397.26
7	97	103.25	32	29	253.26	57	54	403.25
8	98	109.25	33	30	259.26	58	55	409.25
9	99	115.25	34	31	265.26	59	56	415.25
10	14	121.26	35	32	271.26	60	57	421.25
11	15	127.26	36	33	277.26	61	58	427.25
12	16	133.26	37	34	283.26	62	59	433.25
13	17	139.25	38	35	289.26	63	60	439.25
14	18	145.25	39	36	295.26	64	61	445.25
15	19	151.25	40	37	301.26	65	62	451.25
16	20	157.25	41	38	307.26	66	63	457.25
17	21	163.25	42	39	313.26	67	64	463.25
18	22	169.25	43	40	319.26	68	65	469.25
19	7	175.25	44	41	325.26	69	66	475.25
20	8	181.25	45	42	331.27	70	67	481.25
21	9	187.25	46	43	337.26	71	68	487.25
22	10	193.25	47	44	343.26	72	69	493.25
23	11	199.25	48	45	349.26	73	70	499.25
24	12	205.25	49	46	355.26	74	71	505.25

Table D-4: Standard channel table (cont.)

Rec no.	Chan no.	Freq (MHz)	Rec no.	Chan no.	Freq (MHz)	Rec no.	Chan no.	Freq (MHz)
75	72	511.25	92	89	613.25	109	111	715.25
76	73	517.25	93	90	619.25	110	112	721.25
77	74	523.25	94	91	625.25	111	113	727.25
78	75	529.25	95	92	631.25	112	114	733.25
79	76	535.25	96	93	637.25	113	115	739.25
80	77	541.25	97	94	643.25	114	116	745.25
81	78	547.25	98	100	649.25	115	117	751.25
82	79	553.25	99	101	655.25	116	118	757.25
83	80	559.25	100	102	661.25	117	119	763.25
84	81	565.25	101	103	667.25	118	120	769.25
85	82	571.25	102	104	673.25	119	121	755.25
86	83	577.25	103	105	679.25	120	122	781.25
87	84	583.25	104	106	685.25	121	123	787.25
88	85	589.25	105	107	691.25	122	124	793.25
89	86	595.25	106	108	697.25	123	125	799.25
90	87	601.25	107	109	703.25			
91	88	607.25	108	110	709.25			

Table D-5: IRC channel table

Rec no.	Chan no.	Freq (MHz)	Rec no.	Chan no.	Freq (MHz)	Rec no.	Chan no.	Freq (MHz)
0	2	55.25	25	12	205.25	50	46	355.25
1	3	61.25	26	13	211.25	51	47	361.25
2	4	67.25	27	23	217.25	52	48	367.25
3	1	73.25	28	24	223.26	53	49	373.25
4	5	79.25	29	25	229.26	54	50	379.25
5	6	85.25	30	26	235.26	55	51	385.25
6	95	91.25	31	27	241.26	56	52	391.25
7	96	97.25	32	28	247.26	57	53	397.25
8	97	103.25	33	29	253.26	58	54	403.25
9	98	109.25	34	30	259.25	59	55	409.25
10	99	115.26	35	31	265.25	60	56	415.25
11	14	121.26	36	32	271.25	61	57	421.25
12	15	127.26	37	33	277.25	62	58	427.25
13	16	133.25	38	34	283.25	63	69	433.25
14	17	139.25	39	35	289.25	64	60	439.25
15	18	145.25	40	36	295.25	65	61	445.25
16	19	151.25	41	37	301.25	66	62	451.25
17	20	157.25	42	38	307.25	67	63	457.25
18	21	163.25	43	39	313.25	68	64	463.25
19	22	169.25	44	40	319.25	69	65	469.25
20	7	175.25	45	41	325.25	70	66	475.25
21	8	181.25	46	42	331.25	71	67	481.25
22	9	187.25	47	43	337.25	72	68	487.25
23	10	193.25	48	44	343.25	73	69	493.25
24	11	199.25	49	45	349.25	74	70	499.25

Table D-5: IRC channel table (cont.)

Rec no.	Chan no.	Freq (MHz)	Rec no.	Chan no.	Freq (MHz)	Rec no.	Chan no.	Freq (MHz)
75	71	505.25	83	79	553.25	91	87	601.25
76	72	511.25	84	80	559.25	92	88	607.25
77	73	517.25	85	81	565.25	93	89	613.25
78	74	523.25	86	82	571.25	94	90	619.25
79	75	529.25	87	83	577.25	95	92	625.25
80	76	535.25	88	84	583.25	96	92	631.25
81	77	541.25	89	85	589.25	97	93	637.25
82	78	547.25	90	86	595.25	98	94	643.25

Table D-6: HRC channel table

Rec no.	Chan no.	Freq (MHz)	Rec no.	Chan no.	Freq (MHz)	Rec no.	Chan no.	Freq (MHz)
0	2	54.00	13	16	132.00	26	13	210.00
1	3	60.00	14	17	138.00	27	23	216.00
2	4	66.00	15	18	144.00	28	24	222.00
3	1	72.00	16	19	150.00	29	25	228.00
4	5	78.00	17	20	156.00	30	26	234.00
5	6	84.00	18	21	162.00	31	27	240.00
6	95	90.00	19	22	168.00	32	28	246.00
7	96	96.00	20	7	174.00	33	29	252.00
8	97	102.00	21	8	180.00	34	30	258.00
9	98	108.00	22	9	186.00	35	31	264.00
10	99	114.00	23	10	192.00	36	32	270.00
11	14	120.00	24	11	198.00	37	33	276.00
12	15	126.00	25	12	204.00	38	34	282.00

Table D-6: HRC channel table (cont.)

Rec no.	Chan no.	Freq (MHz)	Rec no.	Chan no.	Freq (MHz)	Rec no.	Chan no.	Freq (MHz)
39	35	288.00	61	57	420.00	80	76	534.00
40	36	294.00	62	58	426.00	81	77	540.00
41	37	300.00	63	59	432.00	82	78	546.00
42	38	306.00	64	60	438.00	83	79	552.00
43	39	312.00	65	61	444.00	84	80	558.00
44	40	318.00	66	62	450.00	85	81	564.00
45	41	324.00	67	63	456.00	86	82	570.00
46	42	330.00	68	64	462.00	87	83	576.00
47	43	336.00	69	65	468.00	88	84	582.00
48	44	342.00	70	66	474.00	89	85	588.00
49	45	348.00	71	67	480.00	90	86	594.00
50	46	354.00	72	68	486.00	91	87	600.00
51	47	360.00	73	69	492.00	92	88	606.00
52	48	366.00	74	70	498.00	93	89	612.00
53	49	372.00	75	71	504.00	94	90	618.00
54	50	378.00	76	72	510.00	95	91	624.00
55	51	384.00	77	73	516.00	96	92	630.00
56	52	390.00	78	74	522.00	97	93	636.00
57	53	396.00	79	75	528.00	98	94	642.00

Table D-7: Broadcast channel table

Rec no.	Chan no.	Freq (MHz)	Rec no.	Chan no.	Freq (MHz)	Rec no.	Chan no.	Freq (MHz)
0	2	55.25	23	25	537.25	46	48	675.25
1	3	61.25	24	26	543.25	47	49	681.25
2	4	67.25	25	27	549.25	48	50	687.25
3	5	77.25	26	28	555.25	49	51	693.25
4	6	83.25	27	29	561.25	50	52	699.25
5	7	175.25	28	30	567.25	51	53	705.25
6	8	181.25	29	31	573.25	52	54	711.25
7	9	187.25	30	32	579.25	53	55	717.25
8	10	193.25	31	33	585.25	54	56	723.25
9	11	199.25	32	34	591.25	55	57	729.25
10	12	205.25	33	35	597.25	56	58	735.25
11	13	211.25	34	36	603.25	57	59	741.25
12	14	471.25	35	37	609.25	58	60	747.25
13	15	477.25	36	38	615.25	59	61	753.25
14	16	483.25	37	39	621.25	60	62	759.25
15	17	489.25	38	40	627.25	61	63	765.25
16	18	495.25	39	41	633.25	62	64	771.25
17	19	501.25	40	42	639.25	63	65	777.25
18	20	507.25	41	43	645.25	64	66	783.25
19	21	513.25	42	44	651.25	65	67	789.25
20	22	519.25	43	45	657.25	66	68	795.25
21	23	525.25	44	46	663.25	67	69	801.25
22	24	531.25	45	47	669.25			

Appendix E: Factory Default Settings

This section lists the factory default settings for user definable settings. All programs (presets) are set the same, so only the default setting for one program is shown.

Table E-1: Program default settings

Program item	Default setting
Frequency Table	Broadcast
Channel Number	38
Frequency	615.25 MHz
ZCP State	Off
ZCP Line Number	16 (F1)
ZCP Position	1
Audio 1 Output Mode	Stereo
Audio 2 Output Mode	SAP
AFC State	Off
Sound Trap State	On
Signal Source	RF
BTSC Stereo Noise Threshold	8
BTSC SAP Noise Threshold	8

Table E-2: System default settings

Item	Default setting
Active Program	1
Position Message (IDN command)	Set to ASCII space character
Manual Frequency Response (All frequency steps)	0
User Defined Channel Table (All channels)	200.00 MHz
Serial Mode	RS232
Unit Address	32
RS232 Handshake Status	Enabled
RS485 Termination	Terminated



Glossary

Glossary

Bandwidth

The range of frequencies over which signal amplitude remains constant (within some limit) as it is passed through a system.

Baseband

The composite video signal before it modulates the picture carrier. Composite video that is distributed throughout a studio and is used for recording is at baseband.

Broad Pulses

The vertical synchronizing pulses in the center of the vertical interval. These pulses are long enough to be distinguished from all others and are the part of the signal actually detected by vertical sync separators.

Burst

A small reference packet of the subcarrier sine wave sent on every line of video. Since the carrier is suppressed, this phase and frequency reference is required for synchronous demodulation of the color difference signals in the receiver.

B-Y

One of the color difference signals used in the NTSC and PAL systems. It is obtained by subtracting luminance (Y) from the blue camera signal (B).

Chrominance

The color information in a television picture.

Chrominance Signal

The high-frequency portion of the video signal, that is obtained by quadrature amplitude modulation of a 4.43 MHz (PAL) or 3.58 MHz (NTSC) subcarrier with R-Y and B-Y information.

Composite Video

A single video signal containing all of the necessary information to reproduce a color picture.

CW

Continuous Wave. A separate subcarrier sine wave used for synchronization of chrominance information.

dB (Decibel)

A logarithmic unit used to describe signal ratios. For voltages, $dB = 20 \text{ Log}_{10} (V_1/V_2)$.

Demodulator

In general, any device that recovers the original signal after it has modulated a high frequency carrier. In television, it refers to one of the following descriptions:

1. An instrument, such as the Tektronix DS1001A, which takes video in its transmitted form (modulated onto the picture carrier) and converts it to baseband.
2. The circuits that recover R-Y and B-Y from the composite signal.

Field

Half of the video lines required to produce a full video frame. In interlaced scan systems, such as NTSC and PAL, the information for one video frame is divided into two fields. Two vertical scans overlay the two fields to produce the complete frame. In the complete frame, adjacent video lines in the picture are from alternate fields.

FM

Frequency Modulation. The process by which the frequency of a carrier signal is varied in proportion to the modulating signal, such as an audio signal. In the NTSC and PAL television systems, audio information is transmitted using FM.

Frame

Contains all the information required for a complete picture. For interlaced scan systems, there are two fields in a frame.

Harmonic Distortion

Signal distortion caused by non-linearities in a system. System non-linearities produce multiples of a single frequency signal applied to the the system. Harmonic distortion is evident when a pure sine wave applied to a system produces harmonic content at multiples of the sine wave frequency at the output.

Hum

The undesirable coupling of the 50 Hz (PAL) or 60 Hz (NTSC) power sine wave into other electrical circuits.

IF

Intercarrier Frequency. The first state in converting a broadcast television signal into baseband video and audio.

Intercarrier Sound

A method used to recover audio information. Sound is separated from video by beating the sound carrier against the video carrier, producing a 4.5 MHz (NTSC) or 5.5 MHz (PAL) IF that contains the sound information.

IRE

A unit equal to 1/140 of the peak-to-peak amplitude of the video signal, which is typically one volt. The 0 IRE point is at the blanking level, with the sync tip at -40 IRE and the white extending to +100 IRE. IRE stands for Institute of Radio Engineers, the organization that defined the unit.

Linear Distortion

Distortions that are independent of signal amplitude.

Luminance

The signal (Y) that represents brightness, or the amount of light in the picture. This is the only signal required for black and white pictures. For color systems, it is obtained as a weighted sum ($Y = 0.3R + 0.59G + 0.11B$) of the R, G, and B signals.

Modulated

When referring to television test signals, this term implies that chrominance information is present. (For example, a modulated ramp has subcarrier on each step.)

Modulation

A process that moves information around in the frequency domain in order to facilitate transmission or frequency-domain multiplexing.

Non-Linear Distortion

Signal distortion that does not increase at the same rate as the signal amplitude.

NTSC

National Television System Committee. The organization that developed the television standard currently in use in the United States, Canada, and Japan. Now, NTSC is generally used to refer to that standard.

PAL

Phase Alternate Line. One of the television systems used in Europe and many other parts of the world. The phase of one of the color difference signals alternates from line to line to help cancel out phase errors.

Quadrature AM

A process that allows two signals to modulate a single carrier frequency. Two signals amplitude modulate carrier signals with the same frequency but with a phase difference of 90 degrees (hence the term Quadrature). The two resultant signals are added together before transmission. Both signals are recovered at the receiver by demodulating them 90 degrees apart.

Quadrature Distortion

Distortion resulting from the asymmetry of sidebands used in vestigial sideband television transmission. Quadrature distortion appears when using envelope detection but can be eliminated by using a synchronous demodulator.

RF

Radio Frequency. In television applications, the television signal after the picture carrier modulation process.

RGB

Red, Green and Blue. The three primary colors used in color television's additive color reproduction system. These are the three color components generated by the camera and used by the picture monitor to produce a picture.

SAP

Second Audio Program. Second language transmitted on a separate audio track.

Subcarrier

The high-frequency signal used for quadrature amplitude modulation of the color difference signals. The subcarrier frequency is 3,579,545 Hz (NTSC) or 4,433,618.75 Hz (PAL).

Synchronous Detection

A demodulation process in which the original signal is recovered by multiplying the modulated signal with the output of a synchronous oscillator locked to the carrier.

Termination

An impedance at the end of a transmission line that matches the impedance of the source and of the line itself. Proper termination prevents amplitude errors and reflections. Video systems use 75 Ω transmission lines, so a 75 Ω terminator must be at the end of any signal path. A receiving device connected to the transmission line may provide the necessary termination.

Vertical Interval

The synchronizing information that appears between fields and tells the picture monitor to go back to the top of the screen to begin another vertical scan.

Y

Abbreviation for luminance.

Zero Carrier Reference Pulse (ZCP)

A pulse in the vertical interval which is produced by the demodulator to provide a reference for evaluating the depth of modulation.



Index

Index

A

- Accessories
 - optional, 1-2
 - standard, 1-2
- Address
 - RS485 addresses, B-3
 - setting for RS485 serial communication, 3-11
 - Tektronix, x
- Adjust, frequency response, 3-13
- AFC, remote command, B-12
- Applying power, 1-4, 2-7
- AUD_OUT, remote command, B-13
- AUD_PREF, remote command, B-15
- Audio
 - AUD_OUT remote command, B-13
 - AUD_PREF remote command, B-15
 - BTSC remote command, B-17
 - CHANNEL remote command, B-18
 - input selection, 3-7
 - selecting mode in program, 3-6
 - setting noise threshold, 3-8
 - specifications, A-2
- Audio outputs
 - description, 2-4
 - left, 2-4
 - status display, 2-9

B

- Baud rate, B-1
- BTSC, remote command, B-17

Buttons

- arrow, 2-2
- CONFIG, 2-2
- DISPLAY, 2-2
- enter, 2-2
- left and right, 2-2
- PROGRAM, 2-2
- up and down, 2-2
- use in Configure menu, 3-2

C

- Certifications and compliances, A-4
- CHANNEL, remote command, B-18
- Channel
 - adjusting current program, 2-15
 - assignments in frequency tables, 3-4
 - list of frequency tables, D-1
 - selecting in program, 3-4
- Channel table, configuring, 3-16
- Channel tables, D-1
 - broadcast, D-12
 - CATV HRC, D-2
 - CATV IRC, D-3
 - CATV standard, D-5
 - HRC, D-10
 - IRC, D-9
 - standard, D-7
- Cleaning, the exterior surface, C-2
- Commands, B-12
 - AFC, B-12
 - AUD_OUT, B-13
 - AUD_PREF, B-15
 - BTSC, B-17
 - CHANNEL, B-18

- DISC, B-19
 - FREQ, B-20
 - GC_BYF, B-22
 - GC_CFH, B-21
 - GC_DET?, B-23
 - GC_INT, B-24
 - IDN, B-25
 - LOG, B-26
 - MSG, B-27
 - MSG_C, B-28
 - PATH, B-29
 - PRESET, B-30
 - PWD, B-31
 - RECPRT, B-32
 - REPORT, B-33
 - SETT, B-34
 - STRAP, B-38
 - syntax defined, B-10
 - TUNING, B-39
 - ZCP, B-40
 - Communication
 - serial port, 2-3
 - serial port pin out, B-1
 - serial port protocol, B-1
 - Composite output, description, 2-3
 - Configure
 - AFC mode, 3-7
 - audio noise threshold, 3-8
 - BTSC stereo and SAP noise thresholds, 3-8
 - channel table, 3-16
 - display contrast, 3-15
 - frequency response, 3-13
 - frequency table, 3-4
 - menu hierarchy, 3-1
 - operation, 3-1
 - overview of Configure menu, 3-1
 - programs, 3-3
 - quick guide, 3-2
 - RS232 handshaking, 3-12
 - RS485 address, 3-11
 - RS485 termination, 3-12
 - selecting a channel, 3-4
 - selecting Audio mode, 3-6
 - selecting display modes, 2-8
 - selecting frequency, 3-5
 - selecting from menu, 3-2
 - selecting ZCP, 3-5
 - serial mode, 3-11
 - serial port, 3-11
 - sound trap, 3-8
 - user defined channel table, 3-16
 - Connection
 - serial port pin assignments, B-2
 - to AC power, 1-4
 - Connectors, rear panel, 2-3
 - Contacting Tektronix, x
 - Contrast, adjustment, 3-15
 - Controls, front panel, 2-1
 - Custom channel table, 3-16
 - Custom installation, 1-7
- ## D
- Default settings, E-1
 - Description, of product, 1-1
 - Device address, for RS485 protocol, B-3
 - DISC, remote command, B-19
 - Display
 - adjusting contrast, 3-15
 - description, 2-2
 - Display button, selecting display modes, 2-8
 - Display modes
 - audio output status, 2-9
 - firmware revision, 2-13
 - GCR module status, 2-11
 - instrument identification, 2-12
 - program set up, 2-12
 - selecting, 2-8

system status, 2-8
 temperature status, 2-14

E

Electrical installation, 1-4
 Electrical specifications, A-3
 Environmental characteristics, A-3

F

Factory settings, E-1
 Features
 front panel, 2-1
 rear panel, 2-3
 Firmware, revision display, 2-13
 4.5 MHz output, description, 2-3,
 2-4
 FREQ, remote command, B-20
 Frequency
 adjusting current program, 2-15
 configuring response, 3-13
 FREQ remote command, B-20
 list of tables, D-1
 selecting a table, 3-4
 selecting in program, 3-5
 Front panel
 arrow buttons, 2-2
 CONFIG button, 2-2
 description of features, 2-1
 DISPLAY button, 2-2
 enter button, 2-2
 LCD display, 2-2
 left and right buttons, 2-2
 PROGRAM button, 2-2
 up and down buttons, 2-2
 Fuse
 AC fuse location, 2-3
 replacing, C-2

G

GC_BYP, remote command, B-22
 GC_CFH, remote command, B-21
 GC_DET?, remote command, B-23
 GC_INT, remote command, B-24
 GCR module, status display, 2-11
 Getting started, 1-1
 electrical installation, 1-4
 functional check, 1-8
 mechanical installation, 1-6
 options, 1-2
 product description, 1-1
 standard accessories, 1-2
 ghost cancellation algorithm, 2-6

I

Identification
 IDN remote command, B-25
 of instrument, 2-12
 IDN, remote command, B-25
 IF input, 2-8
 IF output, description, 2-4
 Initialization, at power on, 1-5
 Inputs, RF, 2-4
 Installation
 custom, 1-7
 electrical, 1-4
 functional check, 1-8
 in a system, 1-6
 mechanical, 1-6
 rackmount information, 1-7
 typical configuration, 1-6
 Instrument, firmware revision, 2-13

L

Local state, DISC remote command, B-19
lock/unlock front panel, 2-13
LOG, remote command, B-26

M

Mains source, 1-4
Maintenance
 cleaning, C-2
 replacing the fuse, C-2
Measurements, RF signal strength, 2-9
Mechanical installation, 1-6
MSG, remote command, B-27
MSG_C, remote command, B-28

N

Noise threshold
 remote command BTSC, B-17
 selecting mode in program, 3-8

O

Operating basics, 2-1
Operating procedures, 2-7
Optional accessories, rackmount kits, 1-2
Options, 1-2
Outputs
 4.5 MHz O/P, 2-3, 2-4
 audio, 2-4
 composite, 2-3
 IF O/P, 2-4
 Quad O/P, 2-3

P

Packaging for shipment, C-1
PATH, remote command, B-29
Performance requirements, specifications, A-1
Phone number, Tektronix, x
Physical characteristics, A-3
Pin out, of serial port, B-2
Polling
 for system status, B-7
 PATH remote command, B-29
Power
 AC connector, 2-3
 AC source type, 1-4
 applying, 2-7
 fuse holder, 2-3
 power on procedure, 1-4
 replacing the fuse, C-2
 self tests at power on, 1-5
 setting for AC mains, 1-4
Power requirements, specifications, A-3
PRESET, remote command, B-30
Product support, contact information, x
Program
 adjusting current channel, 2-15
 configuration of programs, 3-3
 how to select, 2-14
 navigating in menu, 2-14
 PRESET remote command, B-30
 RECPRT remote command, B-32
 selecting a channel, 3-4
 selecting a frequency table, 3-4
 selecting the frequency, 3-5
 setting the AFC mode, 3-7
 setting the audio mode, 3-6
 setting the noise threshold, 3-8

- setting the sound trap, 3-8
- setting ZCP, 3-5
- status display, 2-12

Programming

- command syntax, B-10
- command types, B-4
- remote flag, B-4

Programming model, B-2

PWD, remote command, B-31

Q

QUAD output, description, 2-3

R

Rackmounting, 1-7

Rear panel, description of features, 2-3

RECPRT, remote command, B-32

Reference section, 3-1

Remote address, for RS485 protocol, B-3

Remote control, B-1

- command descriptions, B-12
- command syntax, B-10
- command types, B-4
- programming model, B-2
- remote flag, B-4
- sending and receiving data, B-5

Remote flag

- DISC remote command, B-19
- RS485 protocol, B-4

Remote operation flag, RS485 protocol, B-4

Replacing the fuse, C-2

REPORT, remote command, B-33

RF input, 2-8

- description, 2-4
- signal strength, 2-9

RS232

- configuring, 3-11
- handshaking, 3-12
- protocol settings, B-1

RS485

- configuring, 3-11
- device address, B-3
- remote address, B-3
- setting address, 3-11
- special byte codes, B-3
- termination, 3-12

S

Safety certification and compliance, A-5

Safety standards, A-6

SCL protocol, B-2

Self tests, at power on, 1-5

Sending and receiving data, B-5

Serial

- addresses for RS485, B-3
- baud rate, B-1
- command descriptions, B-12
- command syntax, B-10
- command types, B-4
- configuring the port, 3-11
- pin assignments for port, B-2
- port connections, B-1
- port protocol, B-1
- programming model, B-2
- rear panel connector, 2-3
- remote flag for RS485, B-4
- RS232 handshaking, 3-12
- RS485 special byte codes, B-3
- RTS/CTS handshaking, 3-12
- selecting the mode, 3-11
- selecting the port protocol, 3-11
- sending and receiving data, B-5

- setting the port address for RS485, 3-11
- setting unit address for RS485, 3-11
- termination for RS485, 3-12
- Service support, contact information, x
- Set up. *See* Installation
- SETT, remote command, B-34
- Settings, default, E-1
- Shipping information, C-1
- SIGLEV, remote command, B-36
- Signal strength, measuring, 2-9
- Sound trap, selecting mode in program, 3-8
- Specifications
 - audio, A-2
 - certifications and compliances, A-4
 - environmental characteristics, A-3
 - performance requirements, A-1
 - physical characteristics, A-3
 - power requirements, A-3
 - safety certification and compliance, A-5
 - safety standards, A-6
 - valid temperature range, A-1
 - video, A-1
- Standard accessories, 1-2
- Status
 - firmware revision, 2-13
 - instrument identification, 2-12
 - of audio outputs, 2-9
 - of GCR module, 2-11
 - of program set up, 2-12
 - of system display, 2-8
 - temperature, 2-14
- Stored, settings as programs, 2-14
- STRAP, remote command, B-38
- Syntax, definition, B-10

System status display, 2-8

T

- Technical support, contact information, x
- Tektronix, contacting, x
- Temperature, operational status, 2-14
- Termination, for RS485 serial communication, 3-12
- TUNING, remote command, B-39

U

- unlock/lock front panel, 2-13
- URL, Tektronix, x

V

- Video, specifications, A-1
- Video outputs
 - 4.5 MHz O/P, 2-3, 2-4
 - composite, 2-3
 - IF O/P, 2-4
 - quadrature, 2-3

W

- Web site address, Tektronix, x

Z

- ZCP
 - remote command, B-40
 - selecting in program, 3-5
- Zero carrier pulse, setting in program, 3-5